

Uppgjord/Prepared MG	Godkänd/Approved JR	Datum/Date 260401	Ritning Nr./Drawing No. 101650 eng. Page 1(15) ver. 5
-------------------------	------------------------	----------------------	---

Assembly instruction

Mast S1200 and W1200

This assembly instruction has been drawn up in accordance with SS-EN 1090-2 and should be used as guidance for trained installers with expertise in the field of erecting masts and towers.

Scanmast AB reserves the right to make changes, revise and interpret this instruction.

Mailing address
Scanmast AB
Box 121
SE-792 22 Mora

Visiting address
Scanmast AB
Landsvägen 49
SE-792 95 Mora

Website
www.scanmast.com

Telephone
+46 250 292 00

CONTENTS:

1. CASTING FOUNDATION BOLTS IN MAST FOUNDATION	3
1.1 Fixing template 725686	3
2. ASSEMBLY OF SECTIONS	4
2.1 S1200	4
2.2 W1200	5
3. ASSEMBLING PARTS.....	6
3.1 Section joints.....	6
3.2 Placement of the ladder	6
3.3 Security anchoring	7
3.4 Ladder bracket 105209	7
3.5 Ladder joint.....	8
3.6 Cover plate 101578	8
3.7 Assembly instructions wedged slack puller	9
3.8 Tensioning stays	9
3.9 Mounting of slack puller in anchor rock.....	10
4. ERECTING MAST	11
4.1 Assembly of complete mast lying on ground	11
4.2 Erecting mast having completely assembled it on the ground	11
4.3 Joints between base plates and section	11
6. SPECIFICATIONS	13
6.1 Torque for tightening screw joints.....	13
6.2 Torque for tightening foundation bolts	13
6.3 Locking with punch marks	13
6.4 Weight specifications.....	13
7. LIFT POSITION FOR ERECTION OF S1200 MASTS	14
8. LIFT POSITION FOR ERECTION OF W1200 MASTS	14
9. STRAIGHTNESS REQUIREMENT	14
10. PROPOSAL FOR INSPECTION PLAN.	15

1. CASTING FOUNDATION BOLTS IN MAST FOUNDATION

1.1 Fixing template 725686

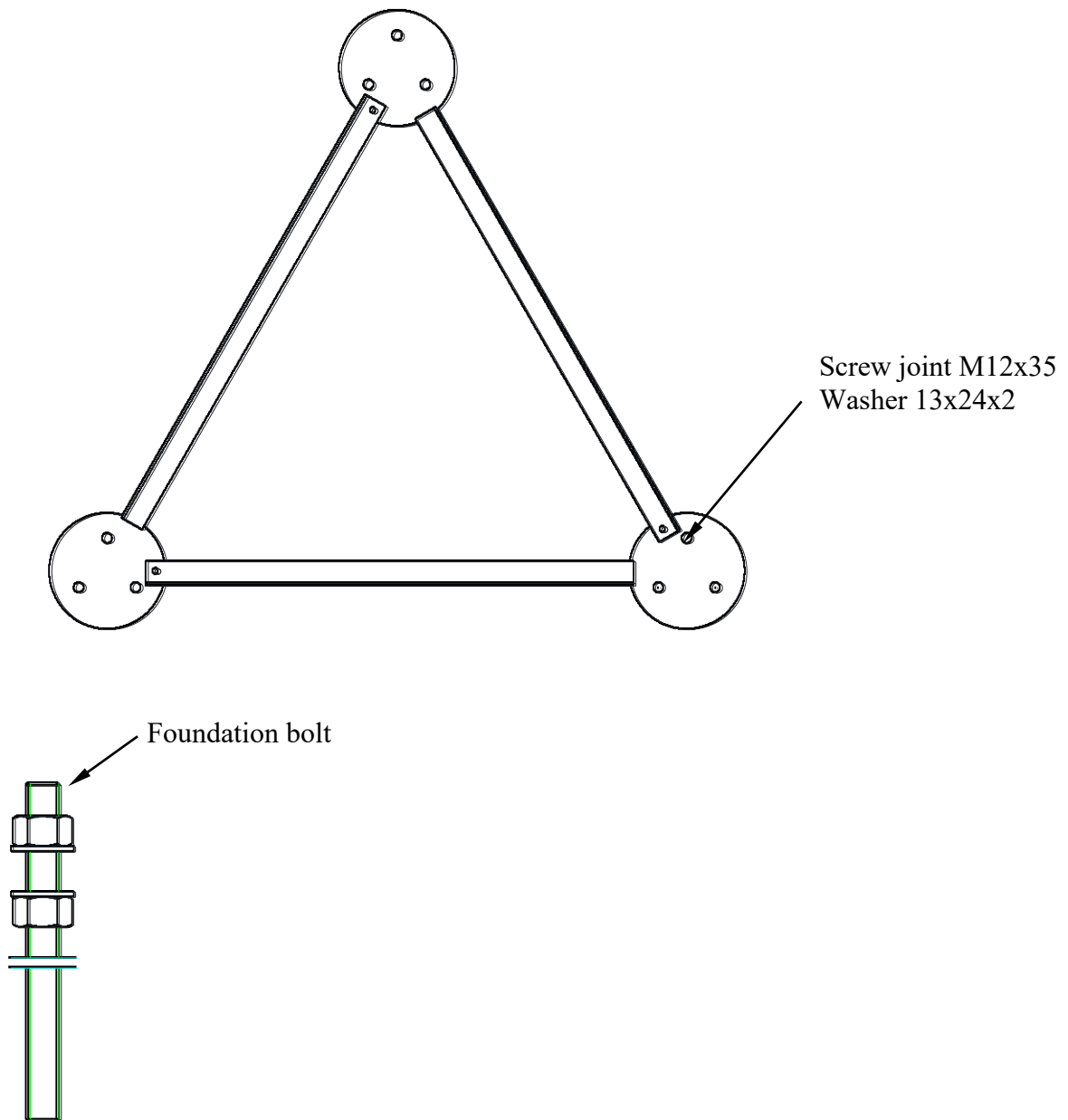

1. Level the top of the casting mould.
2. Place and level the fixing template on the casting mould.
3. Assemble the foundation bolts in the fixing template.
4. Check that the foundations bolts are protruding 150 mm above the surface of the foundation.
5. Tighten the top and bottom nuts against the fixing template.

See separate instruction for further information regarding casting.

Sections 2.1-2.2 and 3.2-3.4 are intended for when the sections are delivered unassembled.

2. ASSEMBLY OF SECTIONS

2.1 S1200

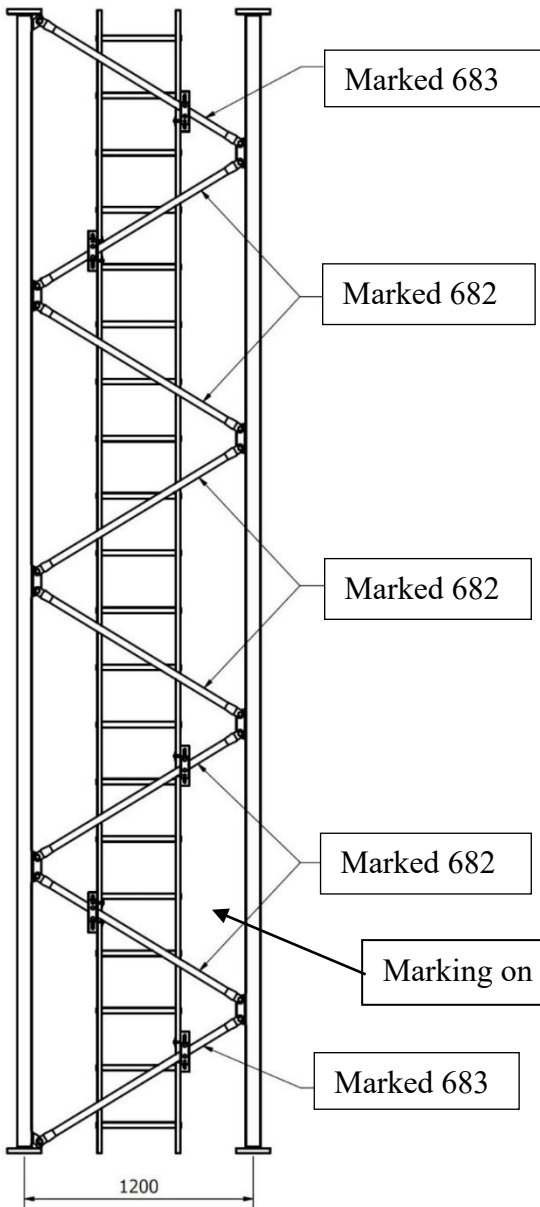

Equipment

Dynamometric wrench, marking paint, mounting brackets, tensioning tool and torque wrench.

General instructions

Check that the racks are parallel.

Check the marking of mast legs and diagonals against the current drawing.

Place mast legs on the racks, the marking on the tower legs should be at the bottom of the section and put in the diagonals, NOTE two different lengths, put in screws, washers and nuts. The diagonals must be turned with the marked side inside the section, the screw joints must be turned with the nut inside the section but the marked side visible. Tighten by hand.

Fit the diagonals to the remaining sides loosely in the first two mast legs and let them lie down, lift up the third mast leg and attach the diagonals to it from one end to the other. Diagonals and screw joints must be turned in the same way as the first side.

Tighten the screws with a torque wrench to the specified torque. Pull "one mast leg at a time" and color-code the screws after each tightened screw.

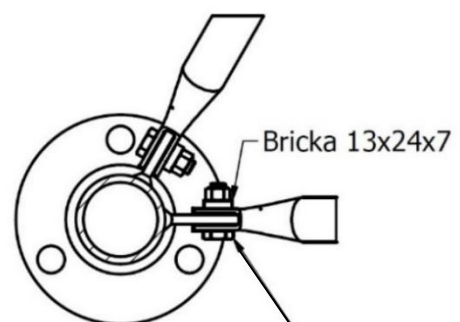

Screw joint SB M12x40

Tightening torque nut M12 87 Nm

Control instructions

Test tightening of 2 screws on each tower leg with a torque wrench in each section.

Ocular control

Check straightness, skewness and that there is no damage to the material and zinc layer.

2.2 W1200

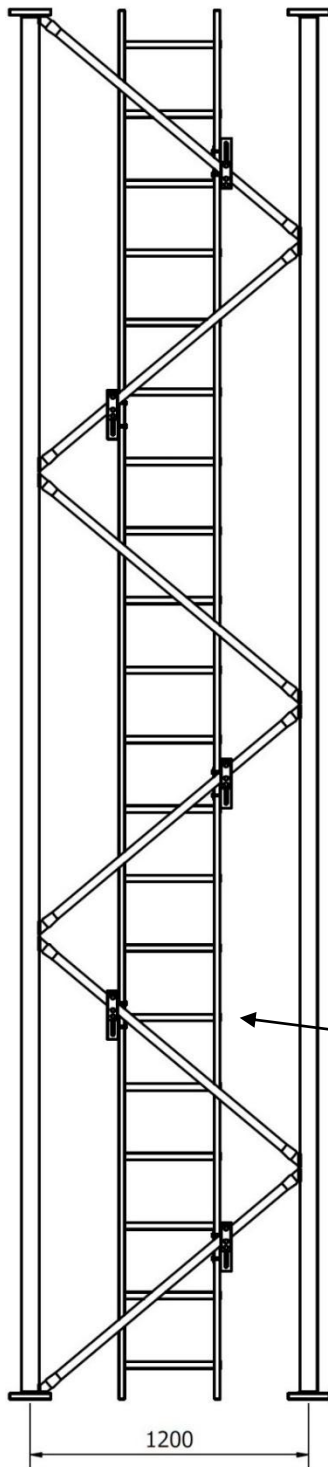

The anchoring mark on the ladder should be downwards in the section.

The fully welded sections must be turned with the marking on the underside of the joint flange downwards. The diagonal direction is then slanted up to the right for the bottom diagonal seen from the outside.

3. ASSEMBLING PARTS

This assembly instruction is intended to supplement a drawing and assumes the mast sections are assembled on delivery.

3.1 Section joints

Ensure that the mast sections are facing downwards (the sections flanges are marked in the bottom end). The lowest diagonal in each section must run from the left and diagonally up to the right.

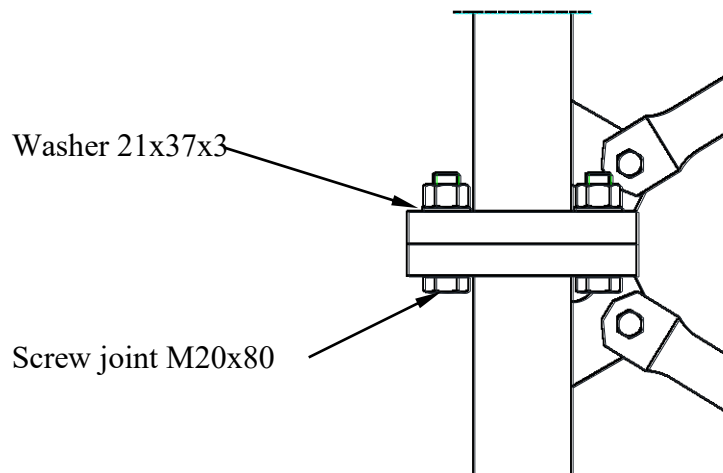

Assemble all the screws in a section joint and tighten before applying torque. Then tighten the screw joints with a torque of 412 Nm (Oiled joint).

3.2 Placement of the ladder

It is important that the ladder is always placed with the anchoring mark (see figure anchoring mark) in the lower part of the section, so that the mark is legible when standing on the ground. The ladder should be placed cantered in the section. When mounting the ladder in the mast, a gap of 5 mm should be left between the ladders.

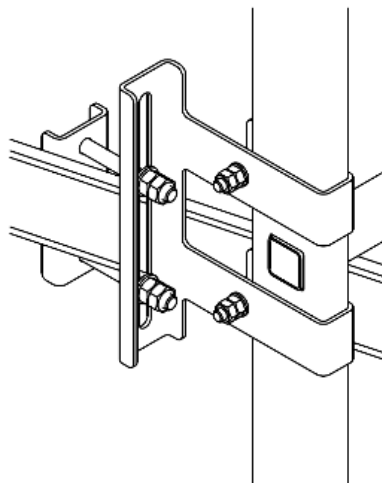
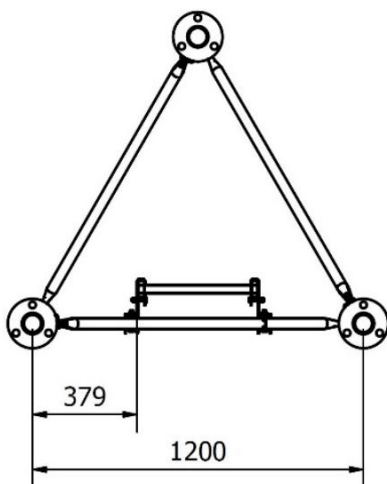

3.3 Security anchoring

The anchoring hook must never be anchored around the rung of the ladder but must always be anchored around the stile of the ladder. See figure "anchoring mark" below.

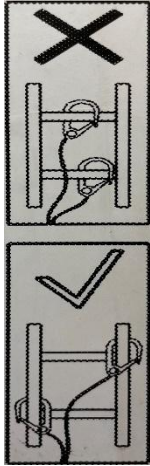

Figure anchoring mark.

3.4 Ladder bracket 105209

Set consisting of 1 ladder bracket. The ladder brackets are placed as shown in the figure below on each section.

Assemble the ladder with the mark on the side of the stile downwards in the section. Position the U-clamps around the stile with its opening towards the diagonal and the angled plate pointing away from the ladder. Assemble with M8-screw, washer and nut. Screw until the distance in the U-clamp is 23 mm and lock with second nut. Put the back plate against the diagonal and assemble with M10, washer and nut. Tighten the nut so the plates or the diagonal does not bend and lock with second nut.

Top view

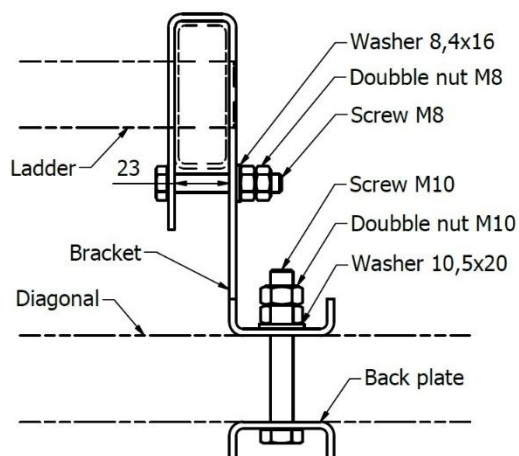

Isometric view

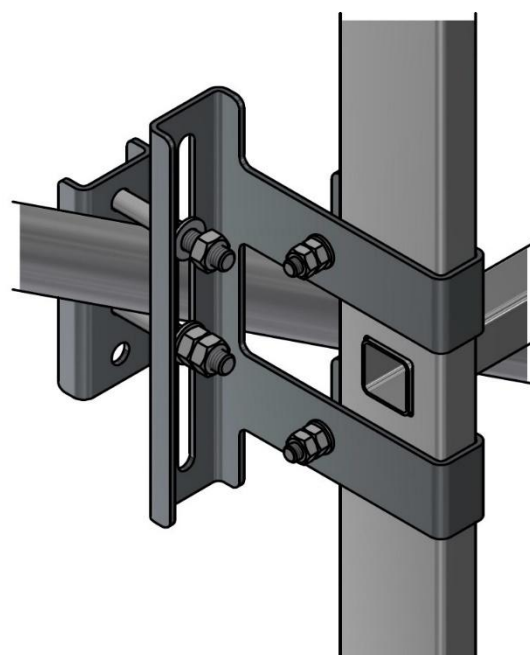

3.5 Ladder joint

When assembling ladder joint 650563, the nut shall be tightened but not so the ladder profile bends. If the tower is erected section by section, ensure that the ladder does not protrude outside the section. If necessary, cut the ladder to size.

External ladder joint

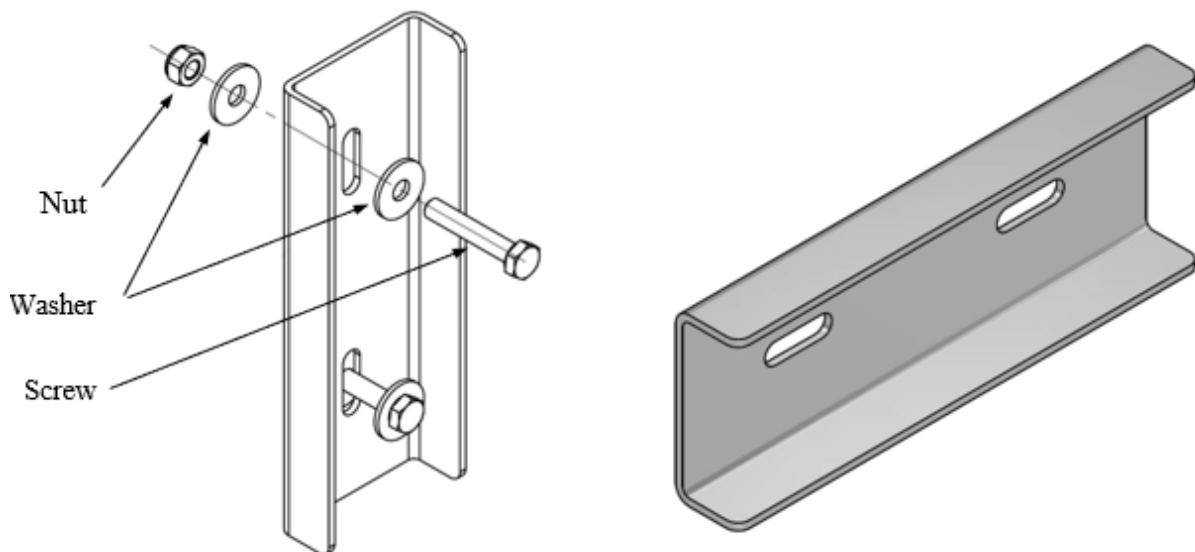

3.6 Cover plate 101578

A cover plate must be installed on each joint flange in the mast top. Secure the nuts with punch marks after tightening.

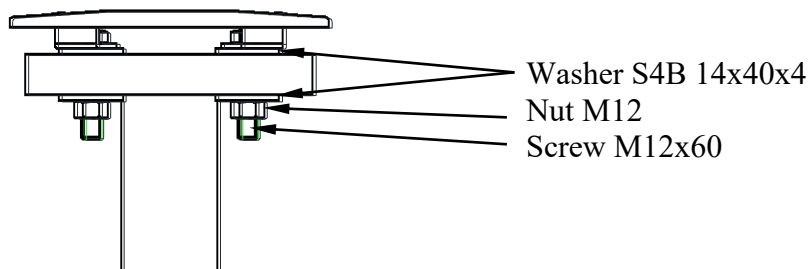

3.7 Assembly instructions wedged slack puller

The surface which slides in the wedge housing is greased with dry film lubricant on delivery.

NB. ENSURE THAT THE SLIDING SURFACES ARE KEPT CLEAN!

NB. ENSURE THAT WEDGE/WEDGE HOUSING AND STAY WIRE ARE KEPT CLEAN!

- Fit the slack puller's U-bolt in the eye of the anchor.
- If a brace is to be used, position it between the U-bolt's legs a maximum of 100 mm from the bottom of the U-bolt (applies solely to slack puller 34194).
- Fit the wedge housing on the U-bolt.
- Convey the stay wire through the wedge housing.
- Stretch the stay wire using the lever winch between gripping jaw and stay hook.
- Move the wedge housing towards the slack puller's nuts.
- Fit the wedge on the cable.
- Move the wedge into the wedge housing.
- Secure the wedge.
- Tighten the fixing screws by the prescribed torque.
- The force is transferred to the stay tighteners through slackening off the lever winch.
- Lash the stay wire a minimum of 25 mm from the wedge. When using an earthing clamp increase the distance to the lashing.
- Cut the cable while lashing.
- Remove the auxiliary tools.

Slack puller number	Fits stay wire area (mm²)	Casing (mm)	Tightening torque (Nm)
34191 -	25 - 68	16	45
34192 -	68 - 105	18	75
34193 -	105 - 142	18	75
34194 -	185 - 284	24	100

See assembly alternative on page 6.

3.8 Tensioning stays

Tension stays as in drawing or other instruction.

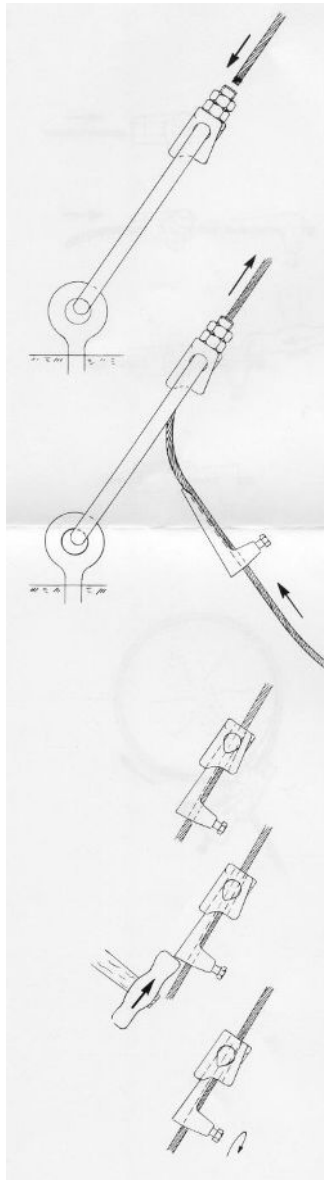

3.9 Mounting of slack puller in anchor rock

When single mount use hole 1 and when double mount use hole 1 and 3, alternative 2 and 3.

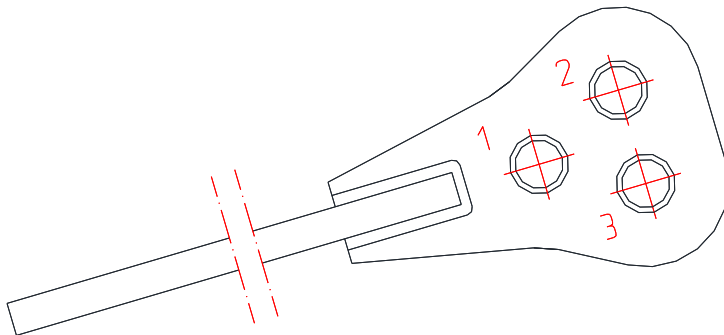

4. ERECTING MAST

4.1 Assembly of complete mast lying on ground

The easiest way to erect the mast is with a mobile crane once it is fully assembled horizontally on the ground. The supports should be levelled to avoid the mast twisting.

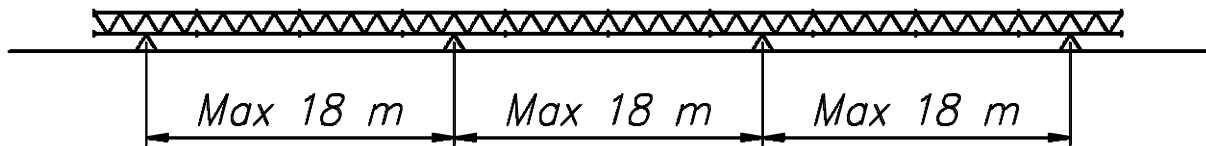

4.2 Erecting mast having completely assembled it on the ground

1. Remove the upper nuts on the foundation bolts and adjust the lower nuts so that their top side is in the same horizontal plane and simultaneously as close to the foundation as possible (approx. 50 mm from the foundation to leave room for under casting).
2. Place a lifting strap adapted to the weight of the mast over the mast's centre of gravity and under a diagonal fixing point See instruction on page 14.
3. Carefully lift the mast with a mobile crane. For masts over 40 m or if the installation engineer is inexperienced, it is recommended that another crane is used to stabilise the bottom end of the mast and prevent it from dragging on the ground
4. Position the mast on the base plates. Screw on the upper nut and tighten with torque.

4.3 Joints between base plates and section

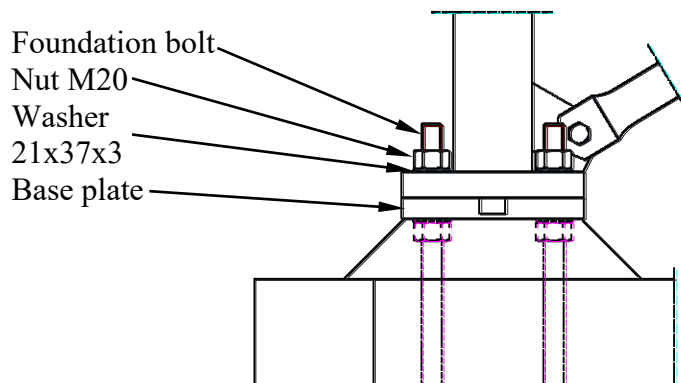

5. UNDERCASTING FOUNDATION

After assembling the mast the base plates must be under cast. Under casting is required so that the mast obtains full load-bearing capacity. Under casting of base plates is performed with a mortar specifically intended for the purpose that has been compensated for shrinkage, for example, BEMIX* expanding frost-proof mortar or equivalent. The under casting must be somewhat smaller in diameter than the base plate so that water cannot collect between mortar and base plate.

NB. Ensure that the drainage channel is open and free of rubbish!

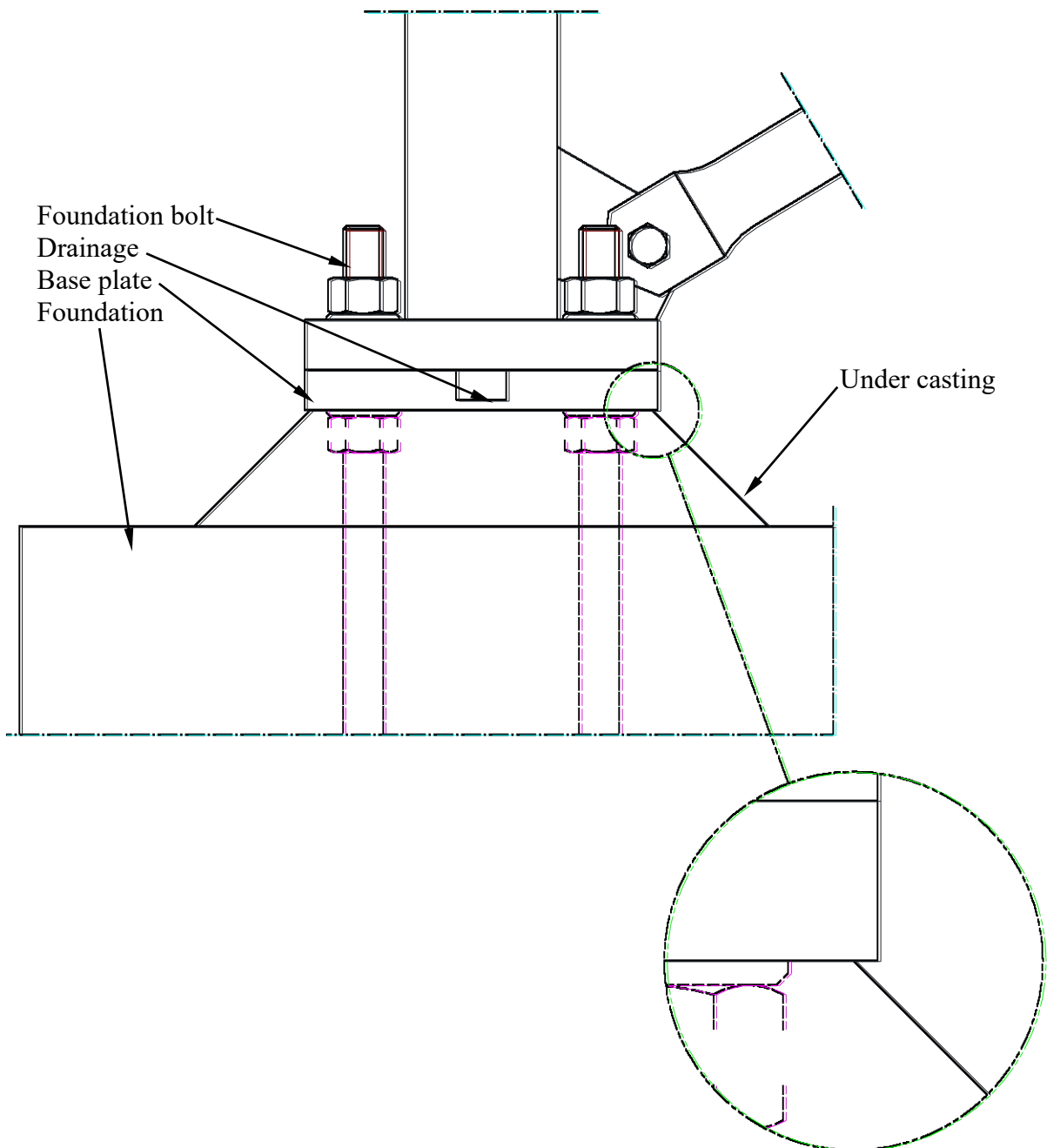

6. SPECIFICATIONS

6.1 Torque for tightening screw joints

Tightening torque, torque wrench

Dimension	Lubricant
	Oil

M12	87 Nm
-----	-------

M20	412 Nm
-----	--------

6.2 Torque for tightening foundation bolts

Tightening torque, torque wrench

Dimension	Lubricant
	Oil

M20	218 Nm
-----	--------

6.3 Locking with punch marks

Joints that are not secured by torquing must be secured by punch marking nuts according to the figure below.

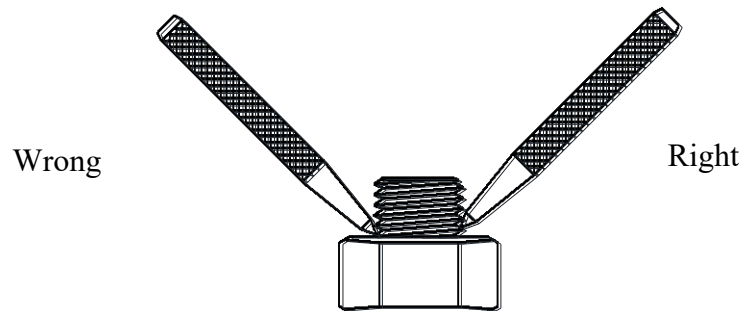

6.4 Weight specifications

Part no.	Name	Weight, kg
100900	Mast section S1200	377
100901	Stay section S1200	412
100902	Stay section S1200	412
100903	Stay section S1200	412
100904	Stay section S1200	412
100948	Mast section W1200	345
100949	Stay section W1200	360

7. LIFT POSITION FOR ERECTION OF S1200 MASTS

Specify the area within which a S1200 mast can be lifted so that it does not exceed its static capacity in any structural element.

The mast is equipped with ladder, cable support, fall protection and a set of panel antennas with accompanying cabling for the lift. The dimensions for the cabling have been assumed as follows: Mast height 0-45 m $7/8''$, 45-60 m $1\frac{1}{4}''$ and 60-90 m $1\frac{5}{8}''$. Lifting a mast without cables and panel antennas is also covered within the range indicated below.

The lift position is given from the bottom of the mast.

Mast height	Lift position
42 m	25-35 m
48 m	30-38 m
54 m	35-42 m
60 m	40-45 m
66 m	44-49 m
72 m	50-52 m

For masts under 42 m it is reasonable to assume that they will not be lifted outside the permissible area as it is within a wide range. No lifting range is therefore specified for masts of less than 42 m.

Masts over 72 m must not be erected in one lift.

8. LIFT POSITION FOR ERECTION OF W1200 MASTS

Conditions: Dimensioning takes place in accordance with relevant ECS. Dimensioning according to elevator and crane standards has not been taken into account. Total safety in ultimate limit state 1.56. Lift of complete mast according to below tables must not take place without supplementary dynamic loads.

The lift position is given from the bottom of the mast.

Mast height	Lift position	Maximum permissible distributed load
60 m	41.5±0.5 m	45 kg/m
66 m	47.0±0.5 m	25 kg/m
72 m	49.7±0.3 m	17 kg/m

For masts lower than 60 m, the lift position shall be selected at 0.7 x mast height. Masts over 72 m must not be erected in a lift.

9. STRAIGHTNESS REQUIREMENT

For assembly, the straightness requirement is one per thousand of the mast's height.

Datum/Date 260401	Ritning Nr./Drawing No. 101650 eng. Page 15(15) ver. 5
----------------------	---

10. PROPOSAL FOR INSPECTION PLAN.

Project:		Inspector:	
Site no.:		Date:	
Site name:		Mast type:	

Inspection before starting assembly	Supplementary information	Sign.
1. Delivery inspection of equipment		
2. Personal protective equipment, safety regulations		
3. Inspection documents for mobile crane/equipment		
4. Torque wrench no.:	Torque wrench no.:	

NB. Inspection plan must be completed on site!

Description of work	Supplementary information	Sign.
1. Tightening foundation bolt + bottom diagonal joint		
2. Tightening 2 x diagonal joints/section		
3. Tightening 1 x flange joint/section		
4. Other bolted joints checked		
5. Mechanical damage		
6. Surface treatment		
7. Any damage touched-up		
8. Cable brackets correctly positioned		
9. Obstruction lights fitted and working		
10. Climbing barrier fitted and working		
11. Fall protection fitted and working	Functional test before use	
12. Earthing correctly executed		
13. Mast/Tower's straightness	Theodolite no.:	
14. Wire ends galvanized / lashed		
15. Stay tensioning		
16. Stay marking kit fitted		
17. Erection site tidied		
18. O light cable mounted		
19. Lightning conductor mounted		
20. Under casting		
21. Warning sign mounted		
22. Site inspection mark put up		
23. Overall assessment/misc./Any defects		