

Assembly instruction

Tower ALTA

This assembly instruction has been drawn up in accordance with SS-EN 1090-2 and should be used as guidance for trained installers with expertise in the field of erecting masts and towers.

Scanmast AB reserves the right to make changes, revise and interpret this instruction.

Mailing address:
Scanmast AB
Box 121
SE-792 22 Mora

Website
www.scanmast.se

Telephone
+46 250 292 00
FAX:
+46 250 140 78

CONTENTS:

1. CASTING FOUNDATION BOLTS IN TOWER FOUNDATION.....	3
1.1 Section 8-10	3
1.2 Section 11-14	4
1.3 Section 15-17	5
1.4 Section 18	6
1.5 Section 19	7
1.6 Section 20	8
2 ASSEMBLING SECTIONS	9
2.1 Fully welded sections 20 and 19	10
2.2 Section 193, 18/183.....	11
2.3 Section 17/171.....	11
2.4 Section 16/161.....	13
2.5 Section 15/151/154/155.....	14
2.6 Section 14/141/145.....	15
2.7 Section 13/131, 12/121, 11/111.....	16
2.8 Section 8, 9, 10, 101, 102.....	17
3 ASSEMBLING PARTS.....	17
3.1 Section joint.....	18
3.2 Placement of the ladder	20
3.3 Safety anchoring	20
3.4 Ladder bracket 105207	21
3.5 Ladder bracket 105208	22
3.6 Cover plate section 20	23
3.7 Ladder joint.....	23
4 ERECTING THE TOWER.....	24
4.1 Erecting tower having completely assembled it on the ground.....	24
4.2 Joints between base plates and section 8-17	26
5. UNDER CASTING BASE PLATES.....	27
5.1 Warranty conditions.....	27
5.2 Section 8-17	27
5.3 Section 18-19-20	27
5.4 Section 20 alternative.....	27
6. SPECIFICATIONS	28
6.1 Torque for tightening screw joints (Does not apply to ladder attachment or flange joints between sections!).....	28
6.2 Torque for tightening foundation bolts	28
6.3 Locking with punch mark	28
6.4 Weight and measure specifications.....	29
7. PROPOSAL FOR INSPECTION PLAN	31
8. OPERATION AND MAINTENANCE	32
8.1 Operation	32
8.2 Maintenance.....	32

1. CASTING FOUNDATION BOLTS IN TOWER FOUNDATION

1.1 Section 8-10

Example pictures Fixing template Section 10 below.

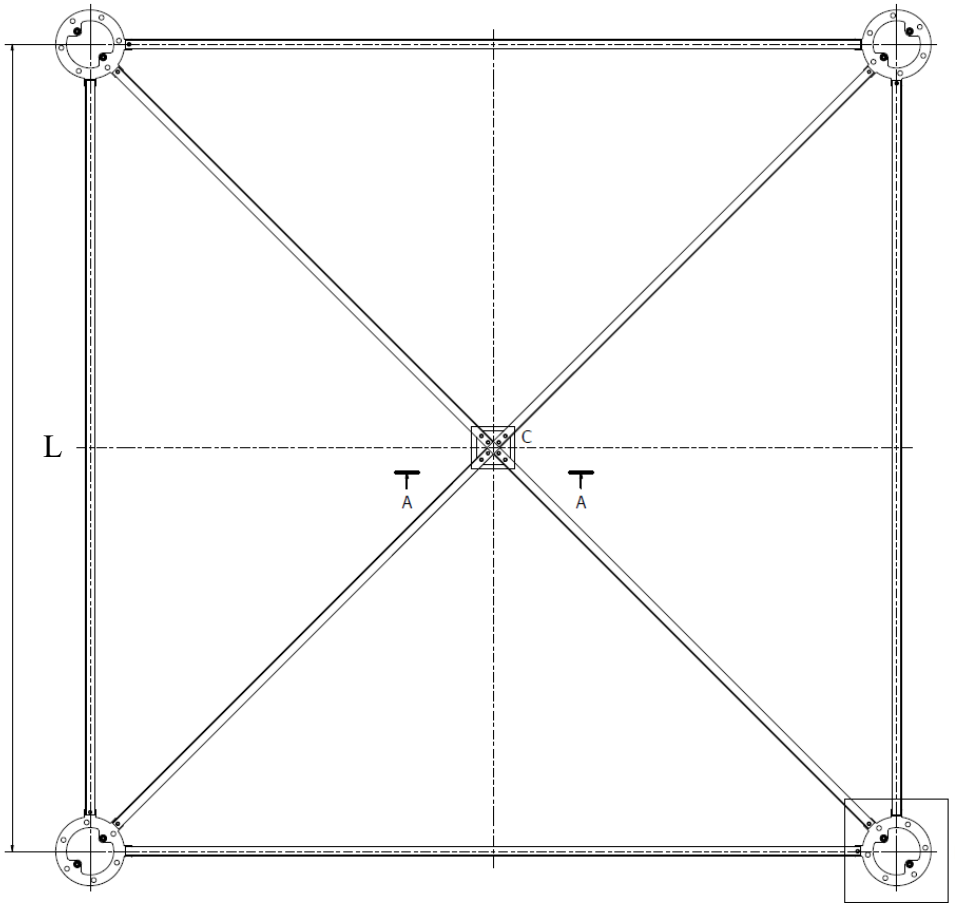

Bolt connection SB
M12x35 incl nut.

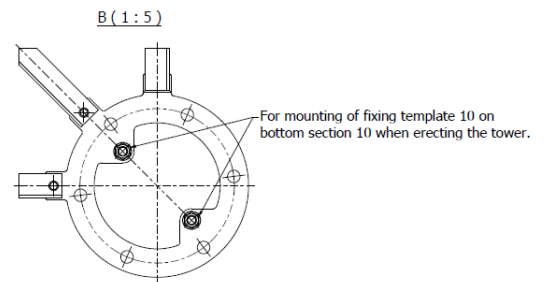
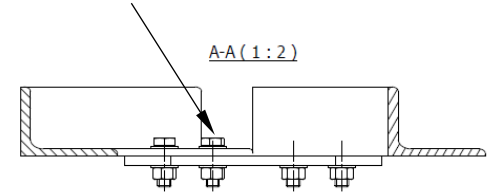

C (1:25)

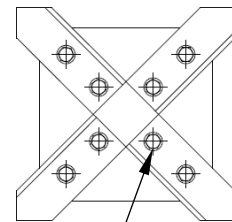

Bolt connection SB
M12x35 incl nut.

Foundation bolt

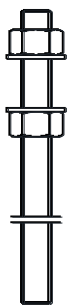

Fixing template Part.no.	Section	L
102265	8	6200
104220	9	5740
104771	10	5280

1. Place and level the fixing template on the casting mould. Turn the "UP" marking on the plate so that it faces upwards.
2. Attach the foundation bolts to the fixing template with the ends marked yellow facing upwards.
3. Check that the foundations bolts are protruding 190 mm above the surface of the foundation.
4. Tighten the top and bottom nuts against the fixing template.

See separate drawing for further instructions regarding casting.

1.2 Section 11-14

Example pictures Fixing template Section 11 below.

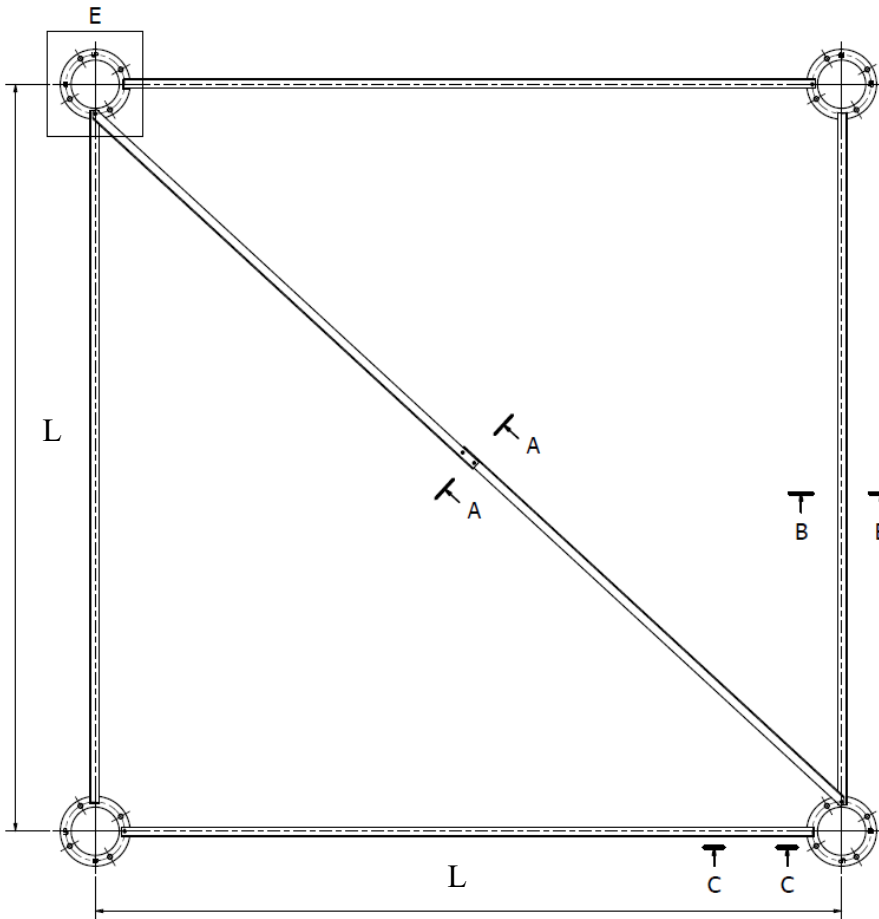

Bolt connection SB
M12x35 incl nut.

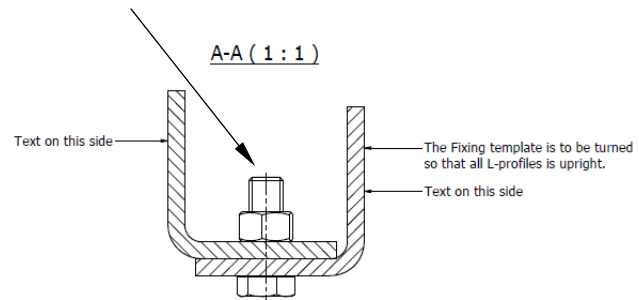

B-B (1:1)

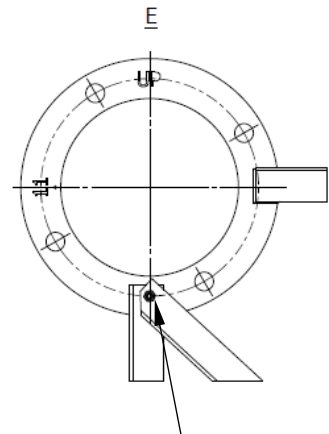
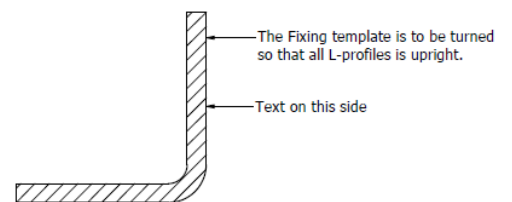

Foundation bolt



Fixing template Part No.	Section	L mm
712670	11	4820
711497	12	4360
711500	13	3900
711503	14	3440

Section	L mm
11	4820
12	4360
13	3900
14	3440

L mm
4820
4360
3900
3440

Bolt connection SB
M12x35 incl nut.

1. Place and level the fixing template on the casting mould. Turn the "UP" marking on the plate so that it faces upwards.
2. Attach the foundation bolts to the fixing template with the ends marked yellow facing upwards.
3. Check that the foundations bolts are protruding 190 mm above the surface of the foundation.
4. Tighten the top and bottom nuts against the fixing template.

See separate drawing for further instructions regarding casting.

1.3 Section 15-17

Example pictures Fixing template Section 15 below.

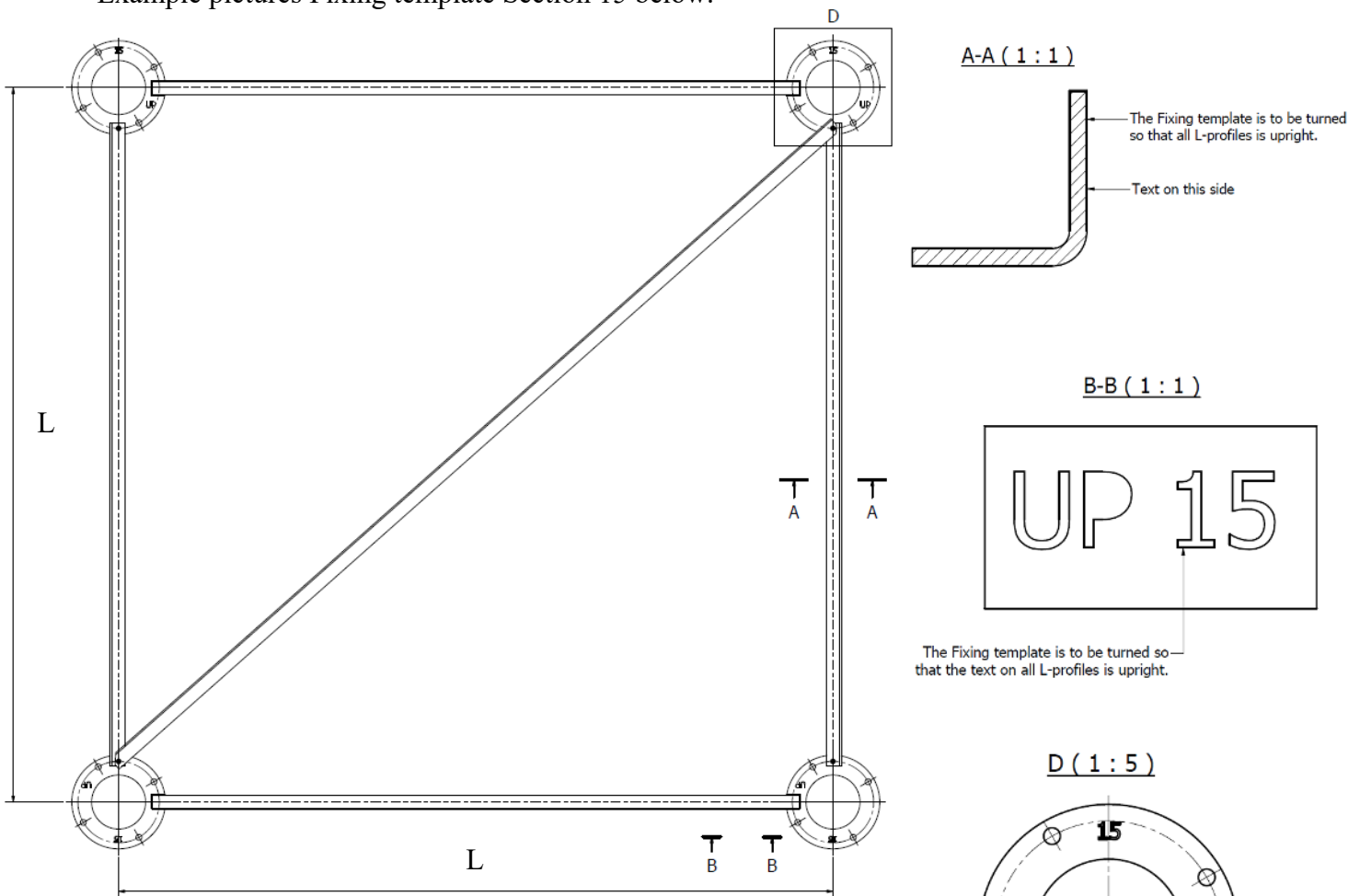

Foundation bolt



Fixing template Part No.	Section	L mm
711514	15	2980
715700	16	2520
715701	17	2060

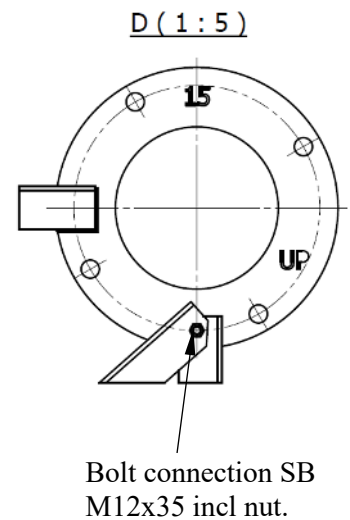

1. Place and level the fixing template on the casting mould. Turn the "UP" marking on the plate so that it faces upwards.
2. Attach the foundation bolts to the fixing template with the ends marked yellow facing upwards.
3. Check that the foundation bolts are protruding 190 mm above the surface of the foundation.
4. Tighten the top and bottom nuts against the fixing template.

See separate drawing for further instructions regarding casting.

1.4 Section 18

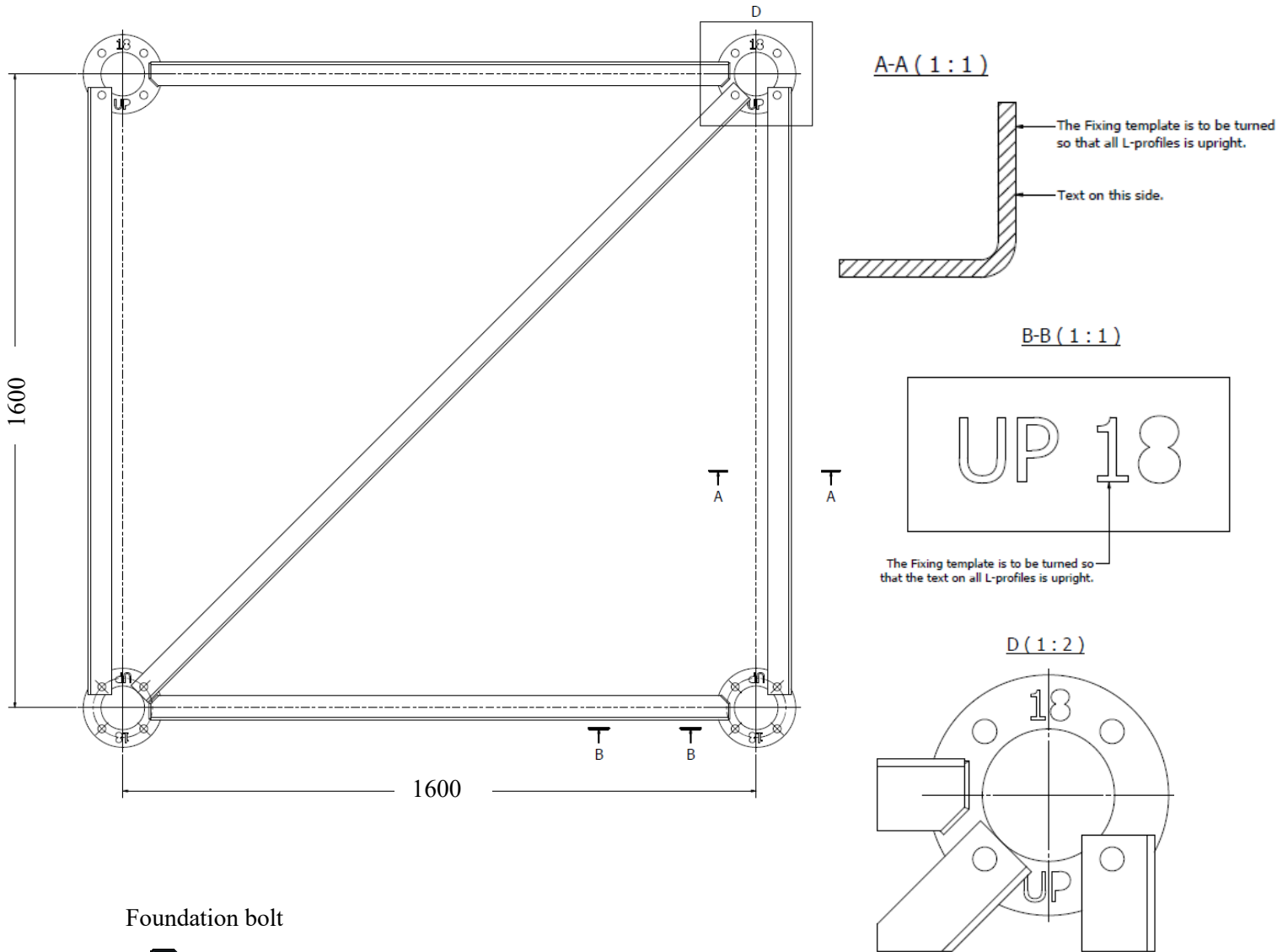

Foundation bolt



Fixing template Part no.	Section	L mm
719785	18	1600

1. Place and level the fixing template on the casting mould.
2. Attach the foundation bolts to the fixing template with the ends marked yellow facing upwards.
3. Check that the foundation bolts are protruding 170 mm above the surface of the foundation.
4. Tighten the top and bottom nuts against the fixing template.

See separate drawing for further instructions regarding casting.

1.5 Section 19

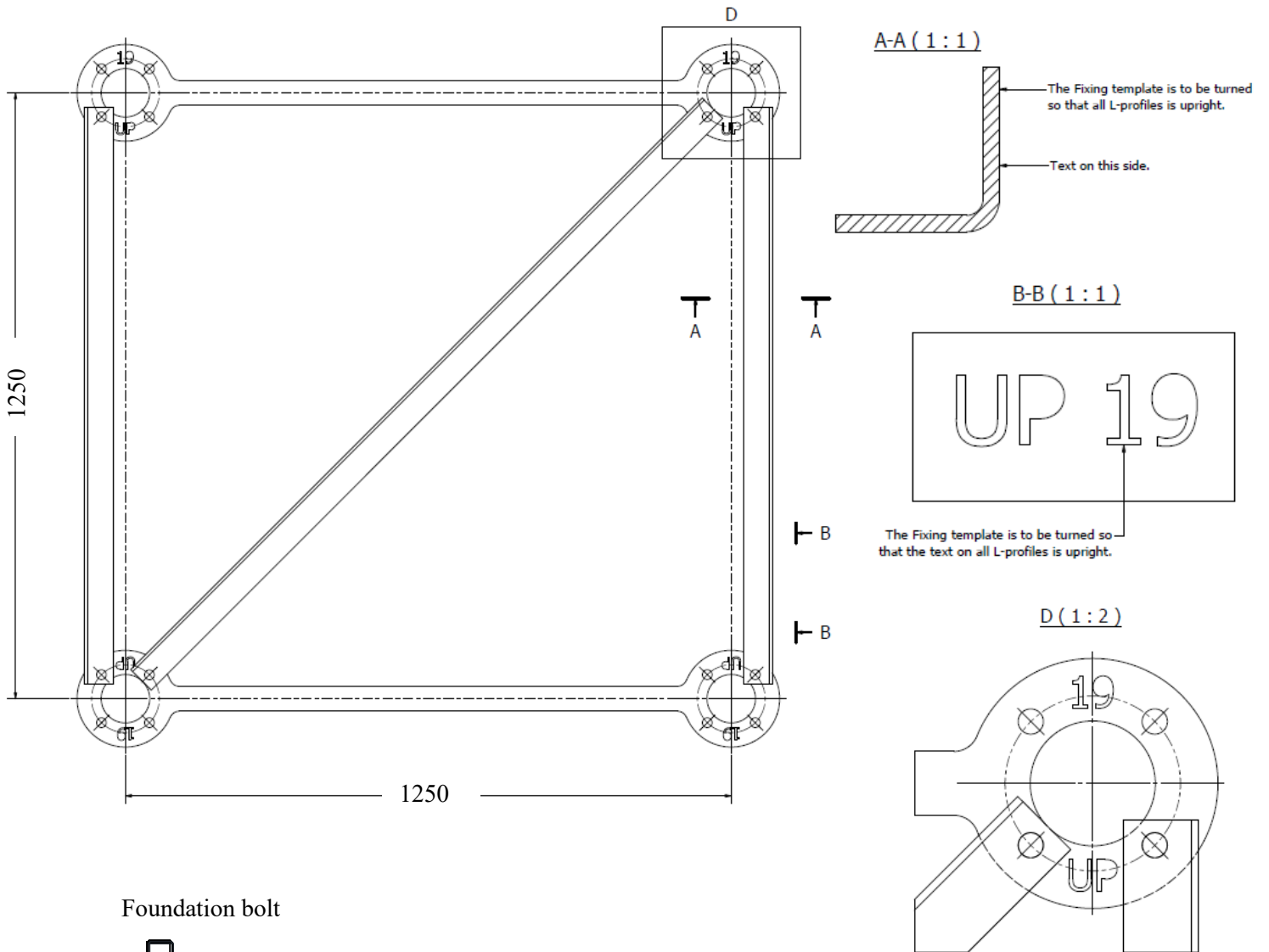

Foundation bolt



Fixing template Part no.	Section	L mm
711166	19	1250

5. Place and level the fixing template on the casting mould.
6. Attach the foundation bolts to the fixing template with the ends marked yellow facing upwards.
7. Check that the foundation bolts are protruding 170 mm above the surface of the foundation.
8. Tighten the top and bottom nuts against the fixing template.

See separate drawing for further instructions regarding casting.

1.6 Section 20

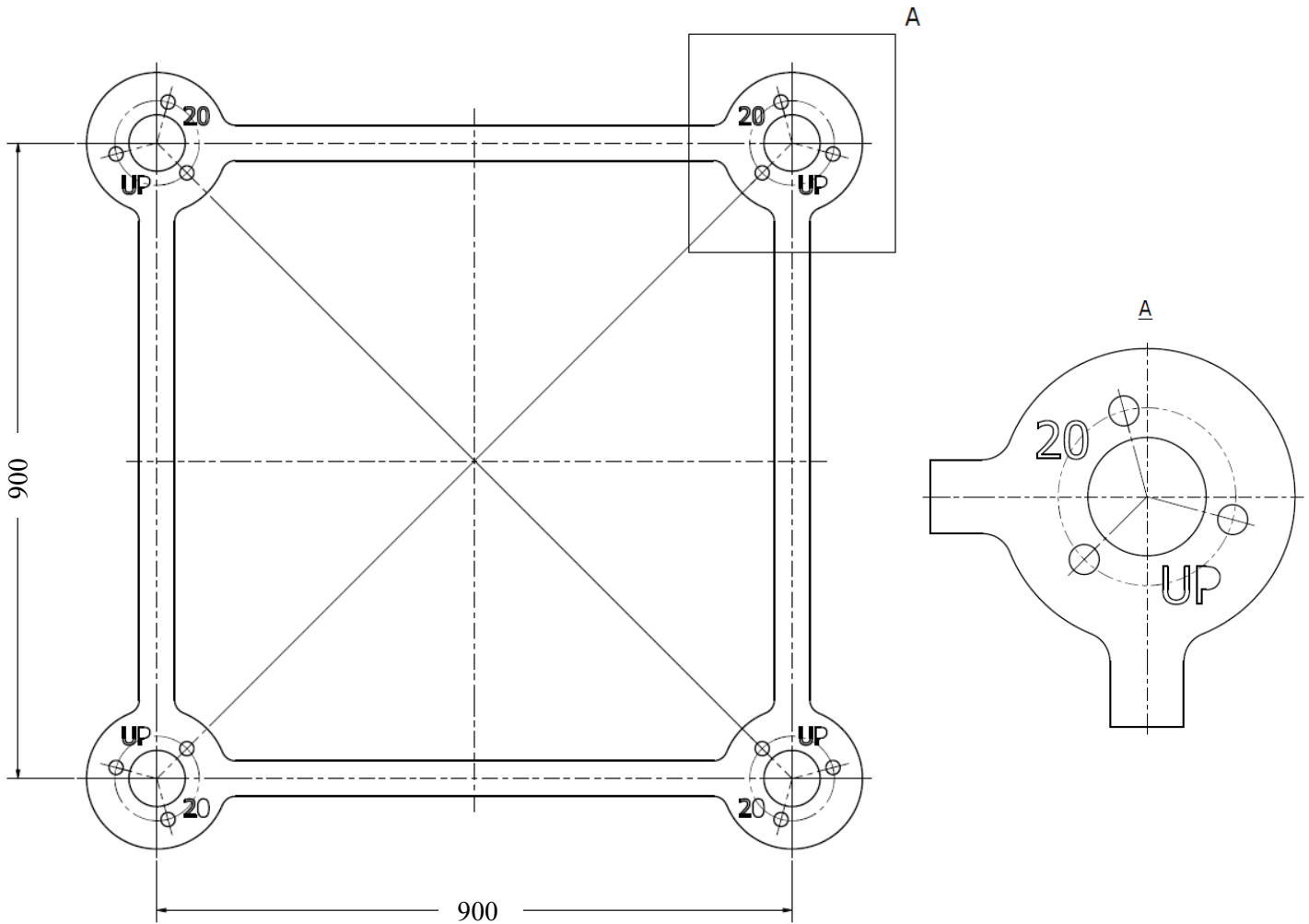

Foundation bolt



Fixing template Part no.	Section
711167	20

1. Place and level the fixing template on the casting mould.
2. Attach the foundation bolts to the fixing template with the ends marked yellow facing upwards.
3. Check that the foundation bolts are protruding 110 mm above the surface of the foundation.
4. Tighten the top and bottom nuts against the fixing template.

See separate drawing for further instructions regarding casting.

2 ASSEMBLING SECTIONS

The easiest way to erect the tower is with a mobile crane once it is fully assembled horizontally on the ground. These instructions assume that sections 19 and 20 are welded and that other sections are assembled on site. The supports should be levelled to avoid the tower twisting.

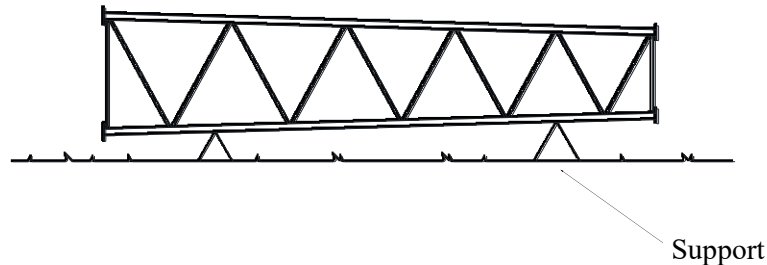

General procedure (assembly instructions for each section are set out in the following pages)

1. Assemble the welded sections.
2. Fit the lower two legs for section 18 to the bottom of section 19.
3. Fit the diagonal which is closest to the higher section which is already completed and proceed with the diagonals "downwards". Create a "floor" in this way.
4. Assemble the two remaining legs with diagonals in the same way on their own supports.
5. Having completed the unit consisting of 2 legs with intermediate diagonals, lift it into position and connect together with section 19.
6. Fit the diagonals in the two remaining sides of the section starting from the top end of the section.
7. Tighten the screw joints for the diagonals with torque. Tighten the screw joints in the section joints with torque and tighten angles according to instructions on pages 15-16.
8. Repeat the above procedure section by section down the tower.
9. Leave the final diagonals closest to the foundation undone until the tower has been placed on the foundation.

Marking

The undersides of the bottom joining flanges on the legs are marked with section numbers. The diagonals are numbered and the marking should be facing upwards.

2.1 Fully welded sections 20 and 19

The fully welded sections shall have the marking on the underside of the joining flanges facing downwards. The direction of the bottom diagonal is then obliquely up to the right (when viewed from the outside of the section).

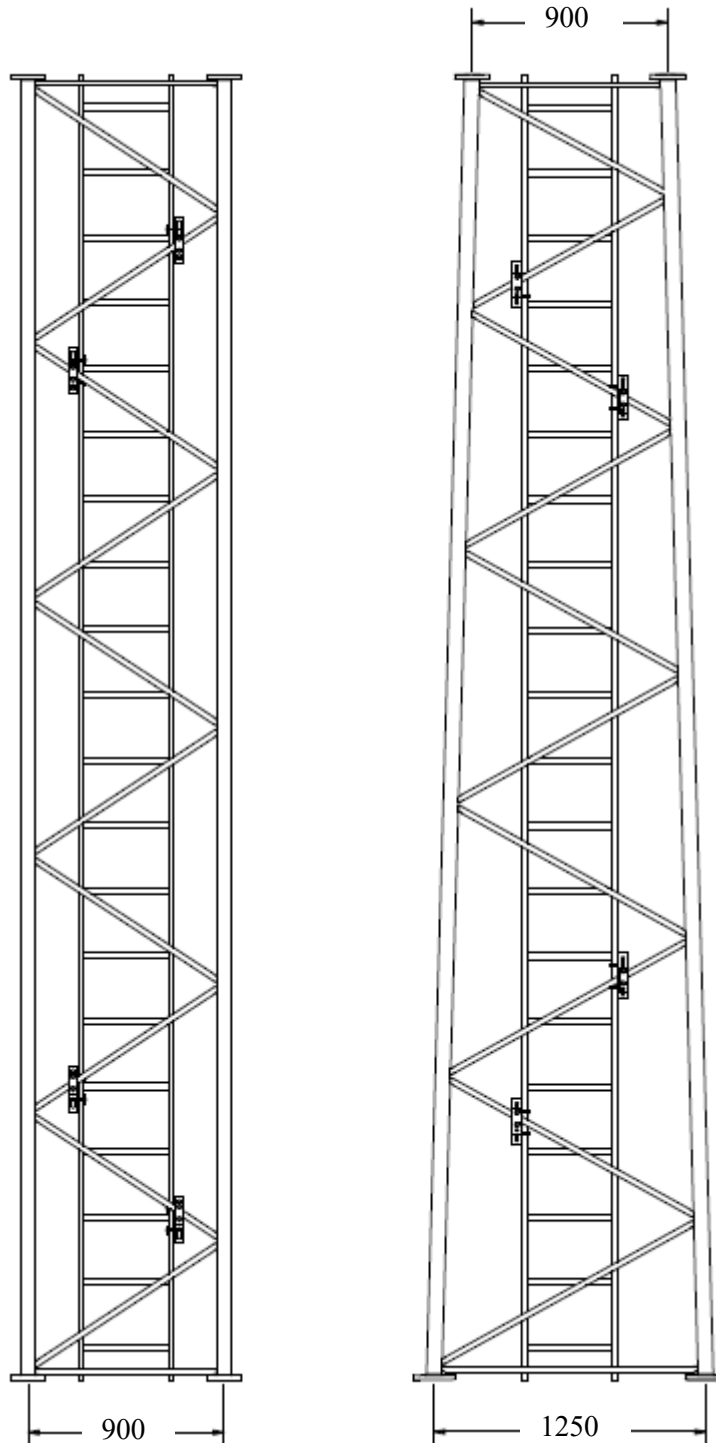

2.2 Section 193, 18/183

All diagonals are marked 190.

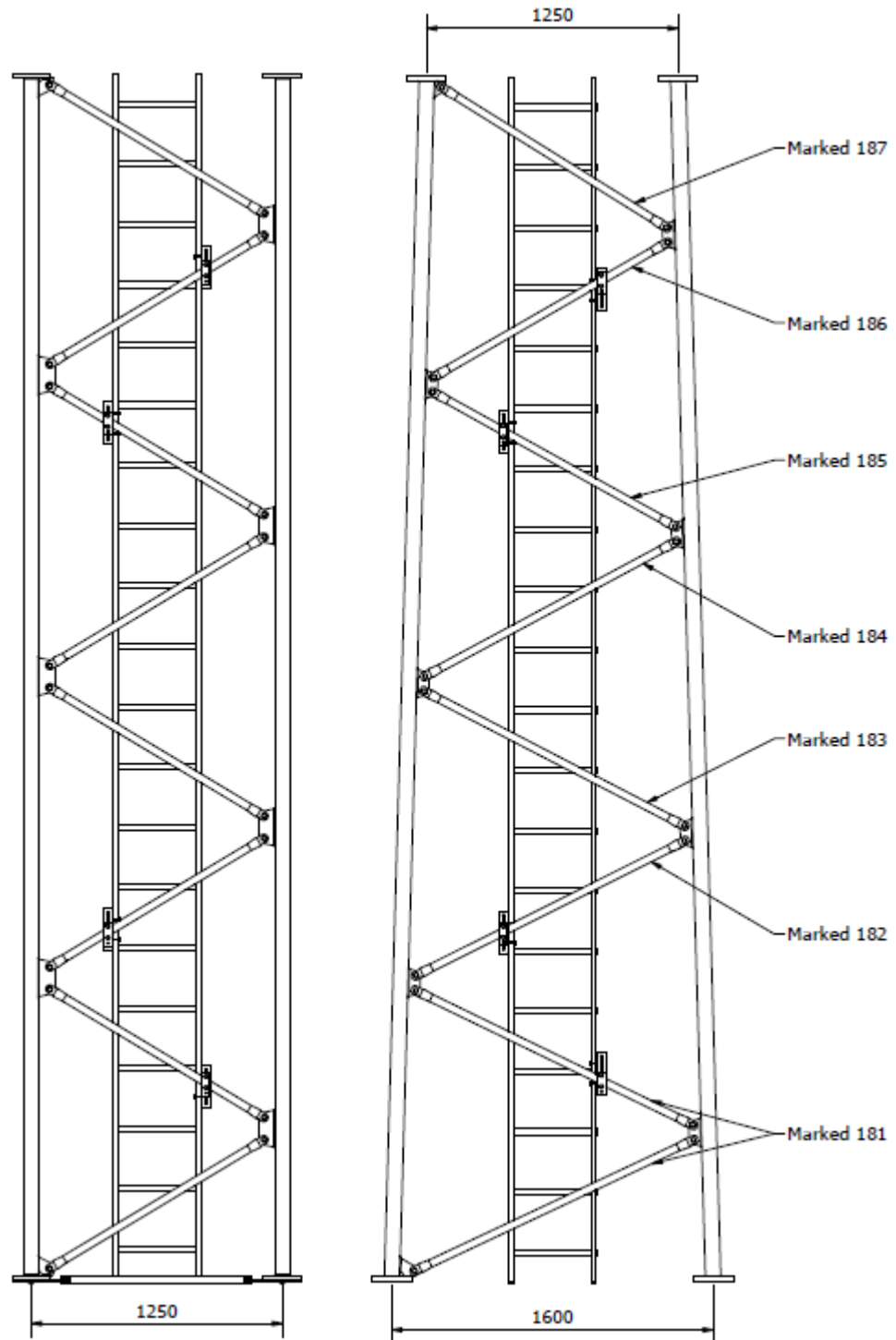

Horizontal bracing to be fitted between section 193 and 18.

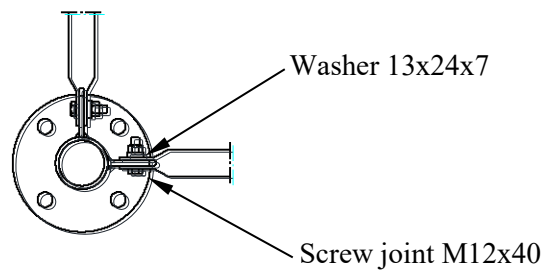

M12 nuts to be tightened with 87 Nm. Assembly instruction for ladder page 20-22.

2.3 Section 17/171

Horizontal bracing to be fitted between section 17 and 18.

Diagonal cross, section 17

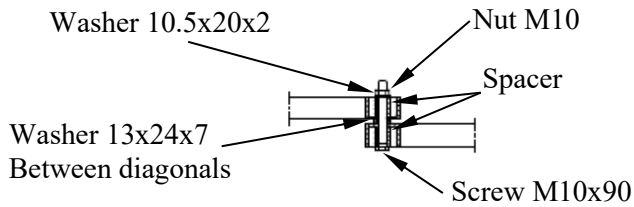

Diagonal cross, section 171

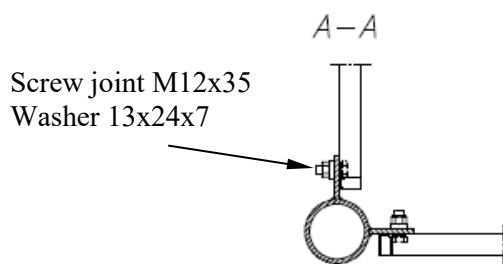
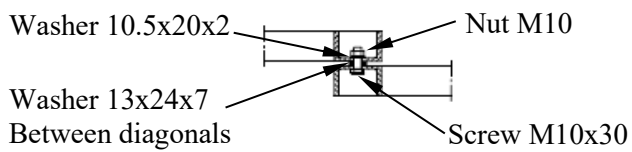

Section 171

Screw joint M12x35
Washer 13x24x7

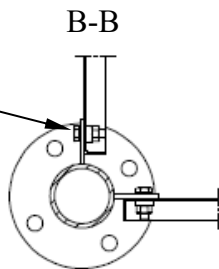

Section 17

Screw joint M12x55
Spacer

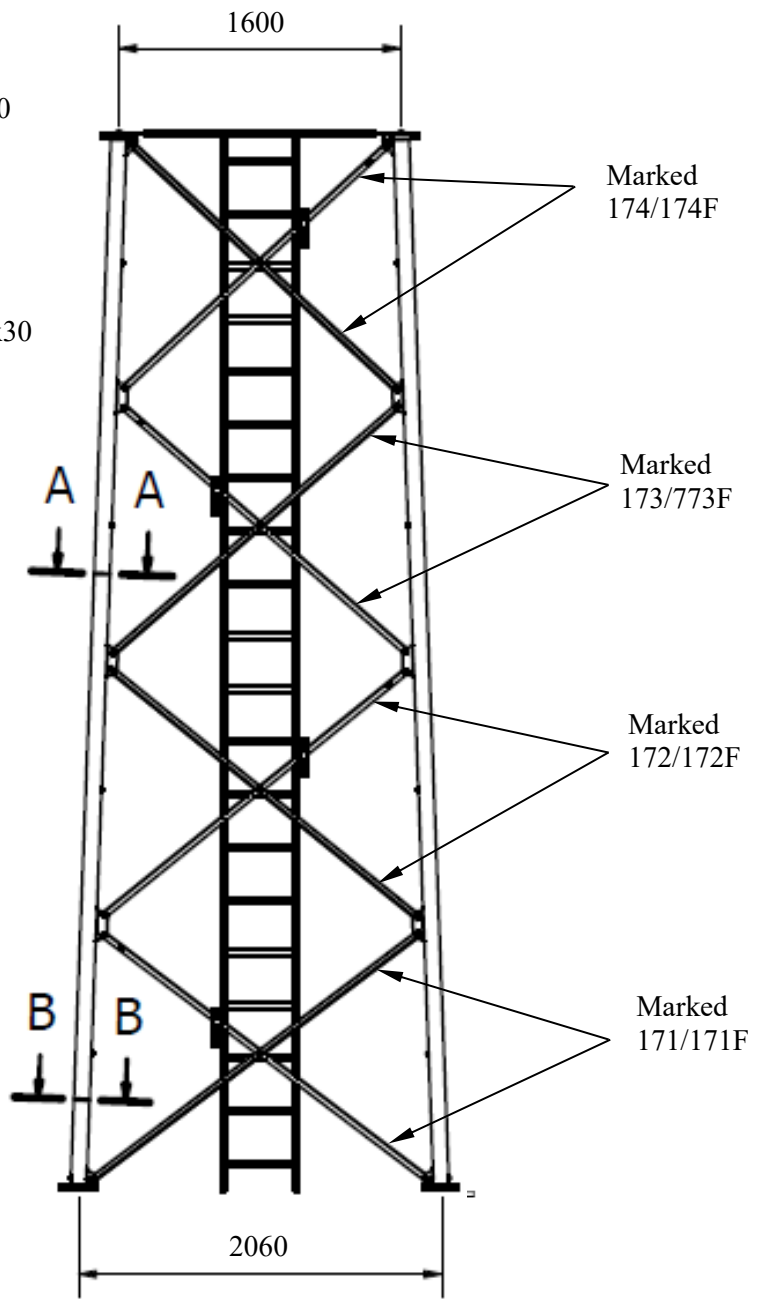
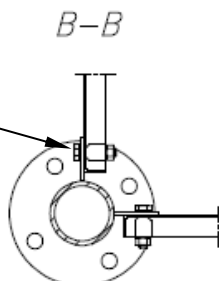

Note that the diagonal in the bottom left corner must be placed to the outside of the diagonal lug, and that the diagonal screws at the very bottom of the section are to be turned the opposite way to the others so that there is access to tighten the flange joints, and that spacer 101082 replaces the washers there.

Nuts M10 are tightened with 50 Nm, M12 with 87 Nm. Assembly instruction for ladder page 20-22.

2.4 Section 16/161

Diagonal cross, section 16

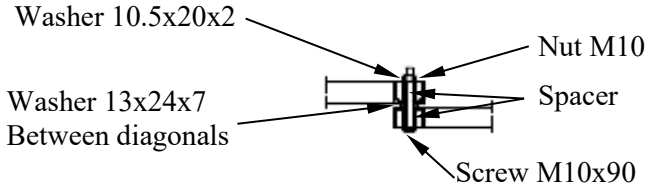

Diagonal cross, section 161

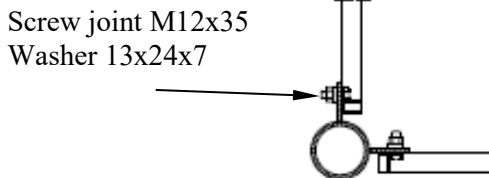
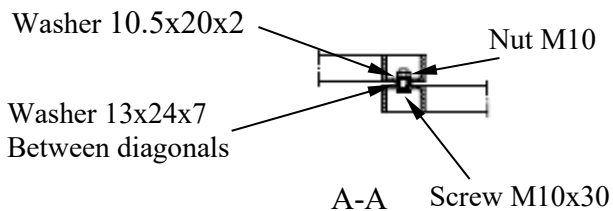

Section 161

Screw joint M12x35
Washer 13x24x7

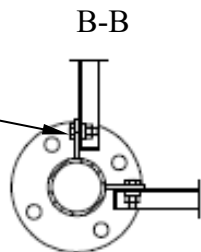

Section 16

Screw joint M12x55
Spacer

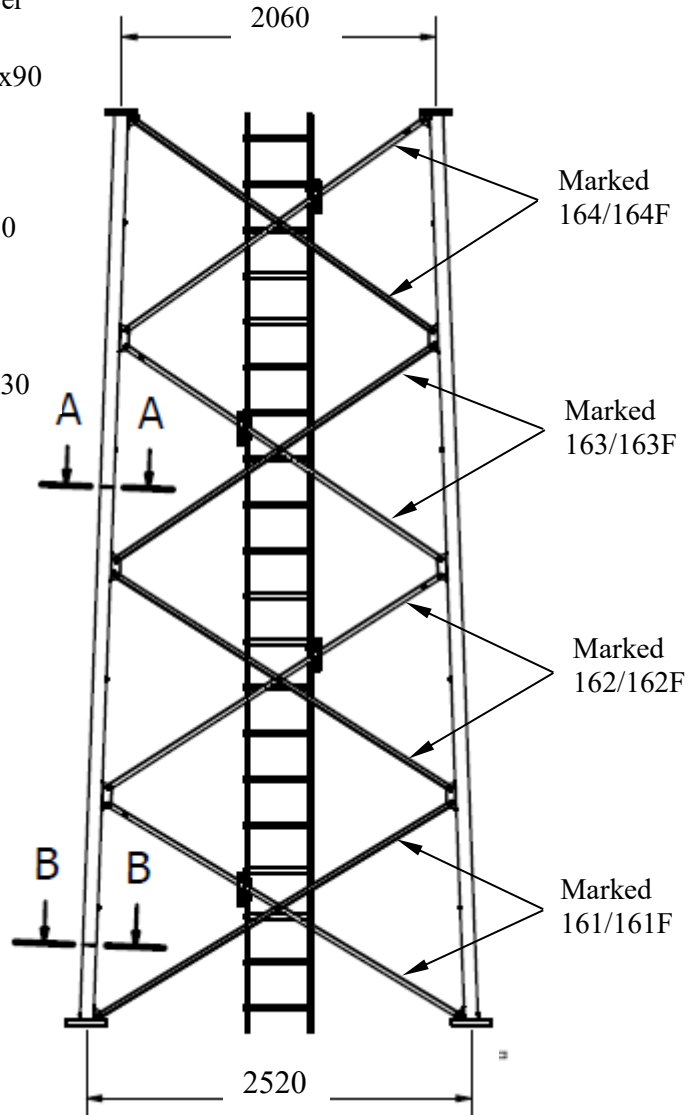
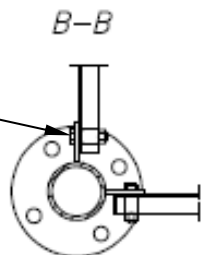

Note that the diagonal in the bottom left corner shall be placed to the outside of the diagonal lug, and that the diagonal screws at the very bottom and very top of the section are to be turned the opposite way to the others so that there is access to tighten the flange joints, and that spacer 101082 replaces the washers there.

Nuts M10 are tightened with 50 Nm, M12 with 87 Nm. Assembly instruction for ladder page 20-22.

2.5 Section 15/151/154/155

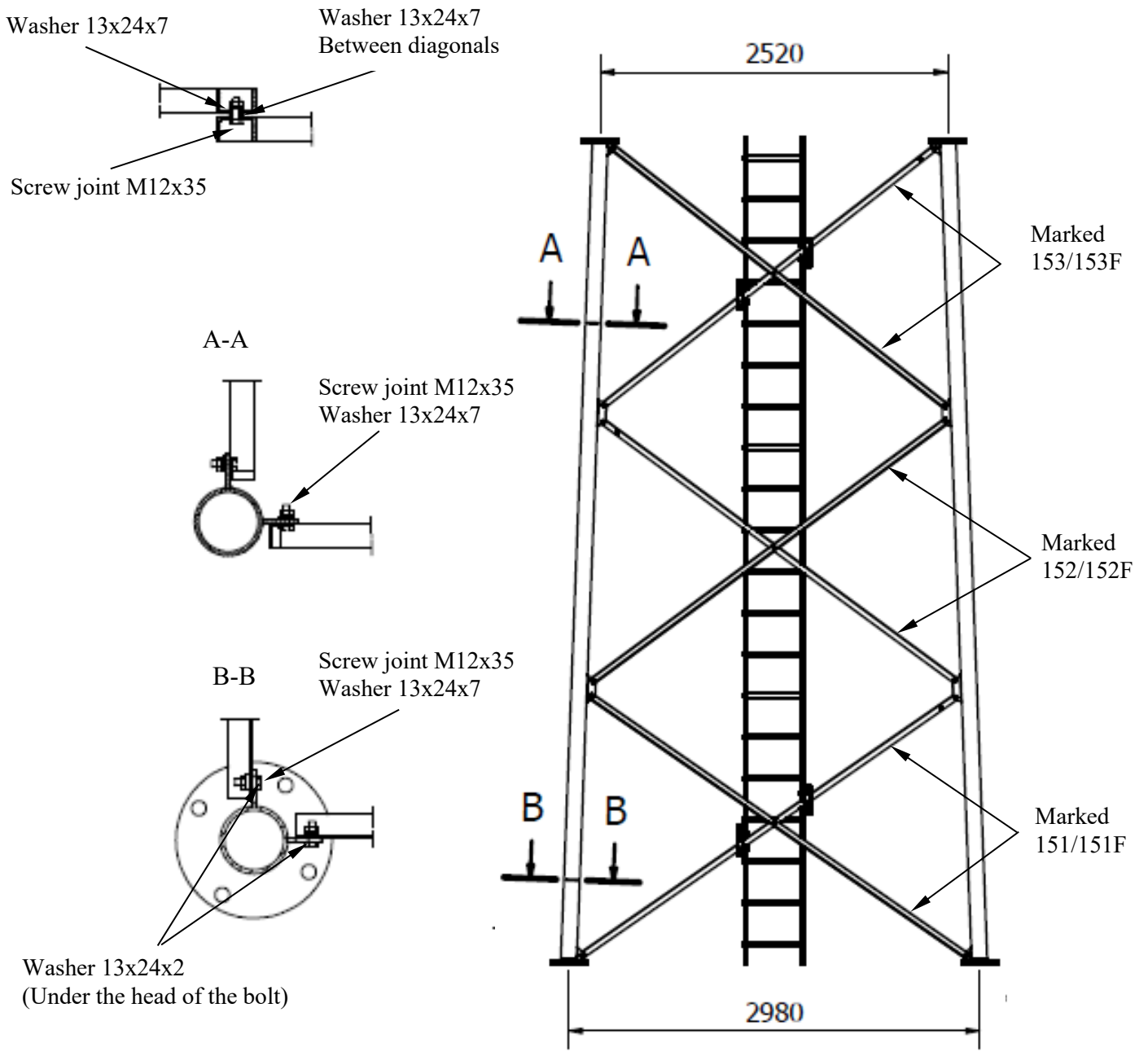

Installation and placement of screw joints and washers at the top joint flange is the same as at the bottom joint flange (Section B-B).

Note that the diagonal in the bottom left corner shall be placed on the inside of the lug, in distinction from the other sections, and that the diagonal screws at the bottom of the section are to be turned the opposite way to the others so that there is access to tighten the flange joints. M12 nuts to be tightened with 87 Nm. Assembly instruction for ladder page 20-22.

2.6 Section 14/141/145

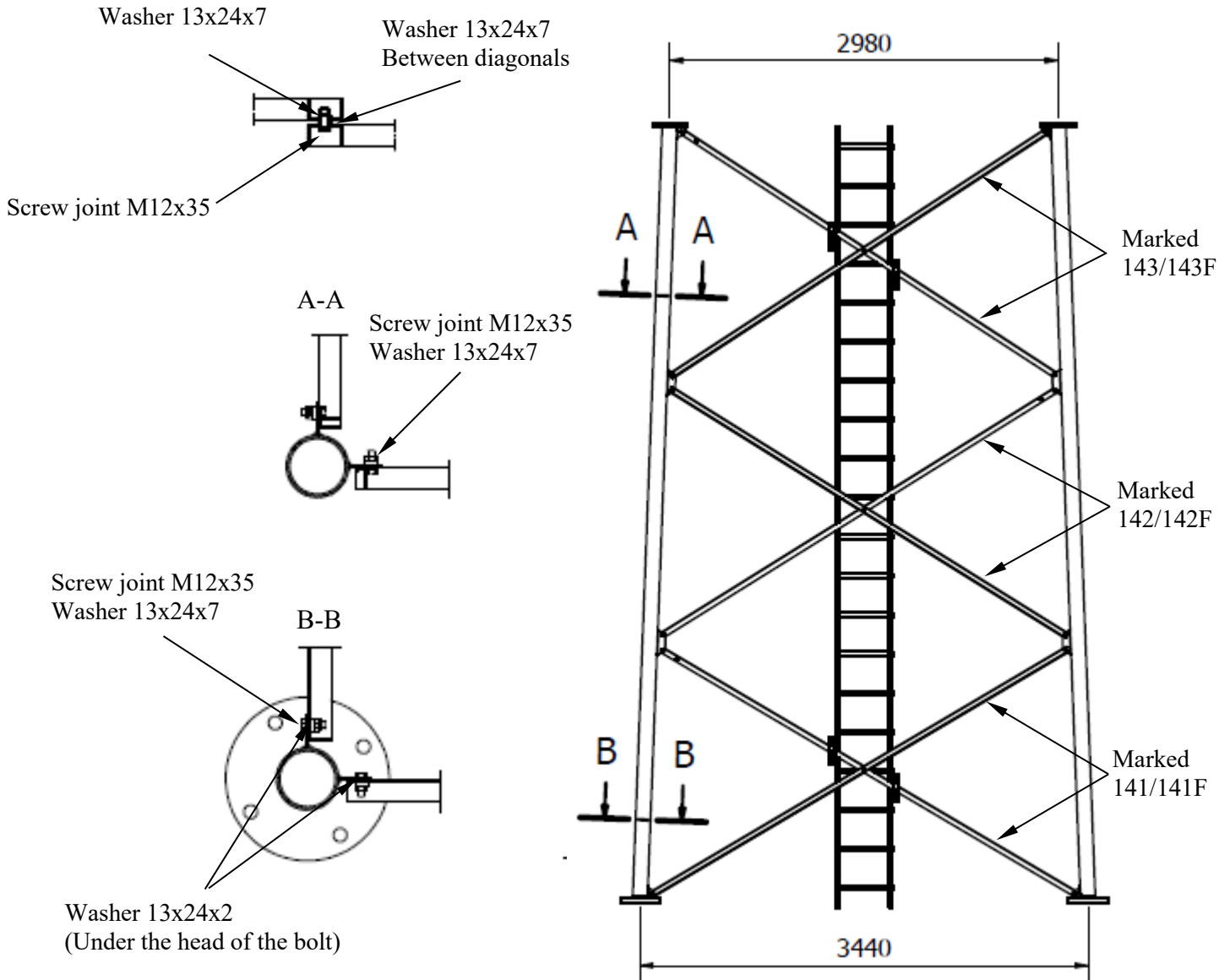

Installation and placement of screw joints and washers at the top joint flange is the same as at the bottom joint flange (Section B-B).

Note that the diagonal in the bottom left corner shall be placed on the outside of the diagonal lug, and that the diagonal screws at the bottom of the section are to be turned the opposite way to the others so that there is access to tighten the flange joints.

M12 nuts to be tightened with 87 Nm. Assembly instruction for ladder page 20-22.

2.7 Section 13/131, 12/121, 11/111

The sections 11/111, 12/121 and 13/131 should be stabilised diagonally using, for example, lashing straps, to avoid handling damage during assembly/lifting.

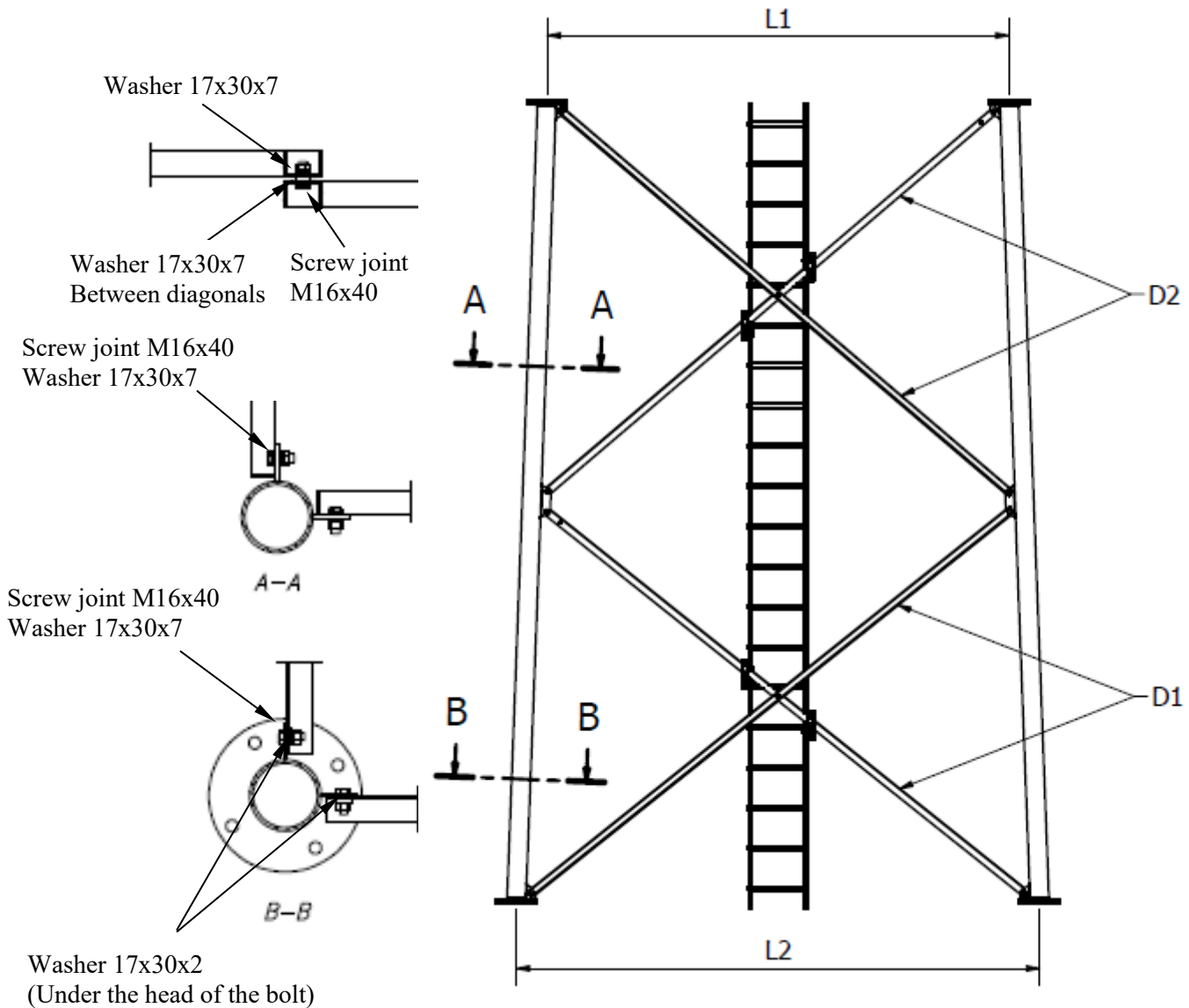

Installation and placement of screw joints and washers at the top joint flange is the same as at the bottom joint flange (Section B-B).

	L1 mm	L2 mm	D1 marking	D2 marking
<u>Section 13/131</u>	3440	3900	131	132
<u>Section 12/121</u>	3900	4360	121	122
<u>Section 11/111</u>	4360	4820	111	112

Note that the diagonal in the bottom left corner shall be placed on the outside of the diagonal lug, and that the diagonal screws at the bottom of the section are to be turned the opposite way to the others so that there is access to tighten the flange joints.

M12 nuts to be tightened with 211 Nm. Assembly instruction for ladder page 20-22.

2.8 Section 8, 9, 10, 101, 102

Section 8, 9, 10, 101 and 102 is to be stabilised diagonally using Fixing templates 8, 9 and 10 according to instruction on page 24-25 to avoid handling damage during assembly/lifting. For mounting details see drawings of section according to table below. Example picture Section 10 below.

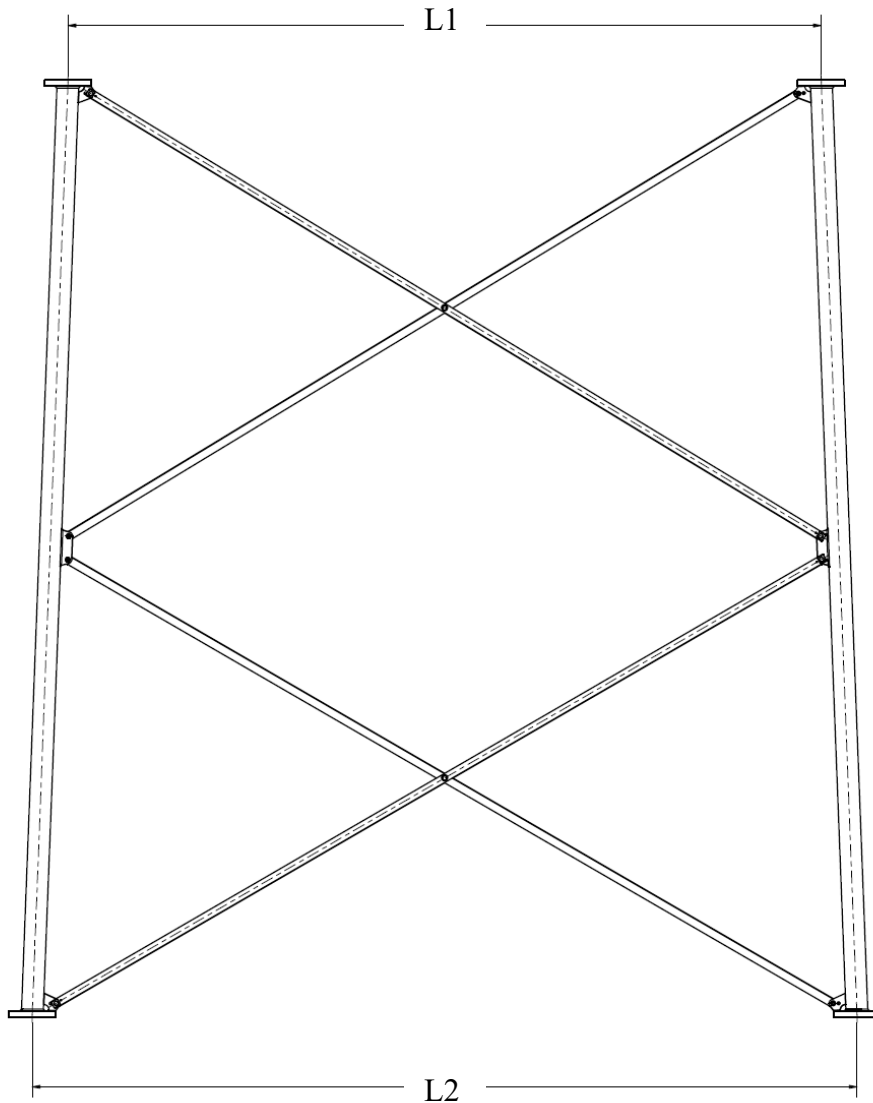

Section	Drawing number Section	L1	L2
8	102242	5740	6200
9	102246	5280	5740
10	102252	4820	5280
101	104803	4820	5280
102	105272	4820	5280

3 ASSEMBLING PARTS

3.1 Section joint

Section 17-18 and 18-193

Other sections

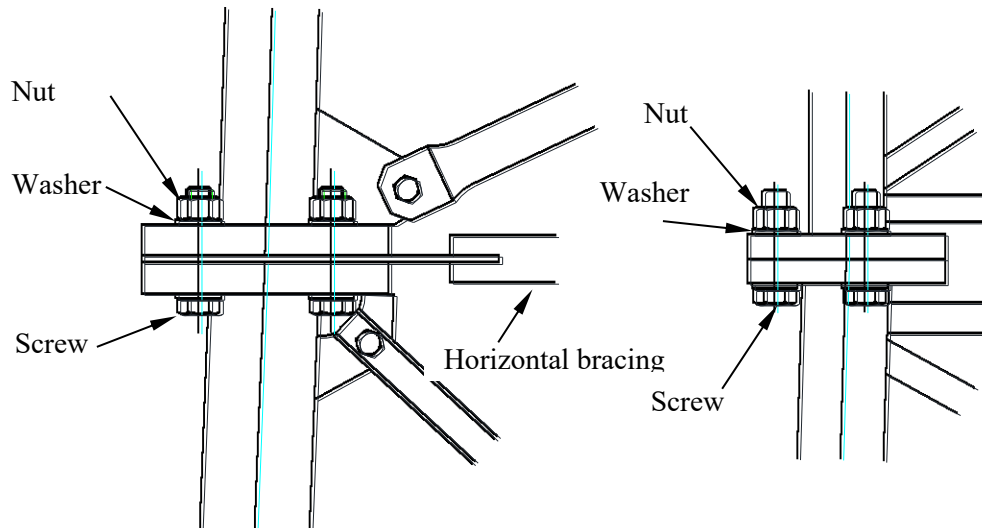

Tightening method HR assembly according to SS-EN 1090-2

Flange joints use a different type of bolted connection and tightening method compared to the other joints. The bolted connection has a tested friction level between the bolt and nut and should not be lubricated further.

It is important to keep the bolted connection in its packaging for as long as possible to prevent the lubricant from being washed away by rain, etc. Pre-assembly of these joints is not permitted. Assembly and final tightening must be carried out during the same operation.

When tightening preloaded joints (HR joints) using the combined method, the bolt assembly is first installed and tightened to normal snug-tight condition (using a standard wrench or impact wrench). The first tightening step in the combined method is to tighten all nuts in the joint to the torque value specified in the table. This can be done with a calibrated torque wrench or torque tool.

Joint	Screw joint	Part No.	Tightening torque
11-12	HR 24x110 8.8/8 galvanized	100862	446 Nm
12-13	HR 24x110 8.8/8 galvanized	100862	446 Nm
13-14	HR 24x110 8.8/8 galvanized	100862	446 Nm
14-15	HR 22x100 8.8/8 galvanized	100867	351 Nm
15-16	HR 22x100 8.8/8 galvanized	100867	351 Nm
16-17	HR 20x 90 8.8/8 galvanized	100871	258 Nm
17-18	HR 20x 90 8.8/8 galvanized	100871	258 Nm
18-19	HR 20x 80 8.8/8 galvanized	100875	258 Nm
19-20	HR 20x 80 8.8/8 galvanized	100876	258 Nm
20-20	HR 20x 80 8.8/8 galvanized	100876	258 Nm

After the first step, the nut's position in relation to the screw threads should be marked with chalk or marking paint so that the final angle of rotation can be easily read. The second tightening step is then to angle-tighten all nuts an additional 60° to achieve the correct preload in the joint.



0°



60°

If a torque tool capable of combining the first and second tightening steps in a single operation is used, the completed assembly is marked by marking the end of the bolt.



0°

3.2 Placement of the ladder

It is important that the ladder is always placed with the anchor mark (see figure anchor mark) in the lower part of the section, so that the mark is legible when standing on the ground. The ladder should be placed centered in the section. When mounting the ladder in the tower, a gap of 5 mm should be left between the ladders.

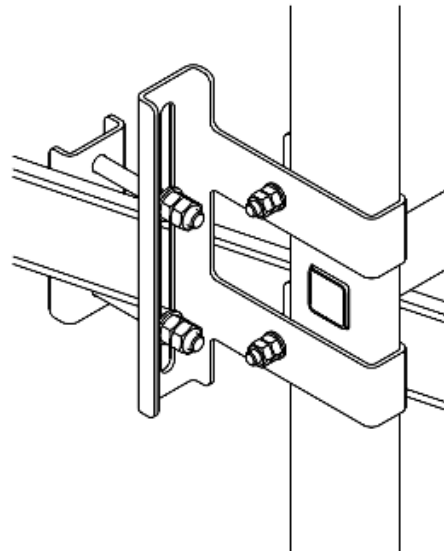
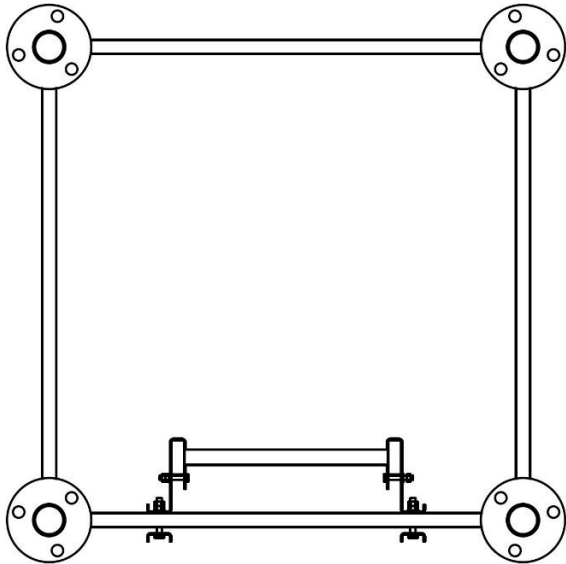

3.3 Safety anchoring

The anchoring hook must never be anchored around the rung but must always be anchored around the stile of the ladder. See figure "anchoring mark" below.

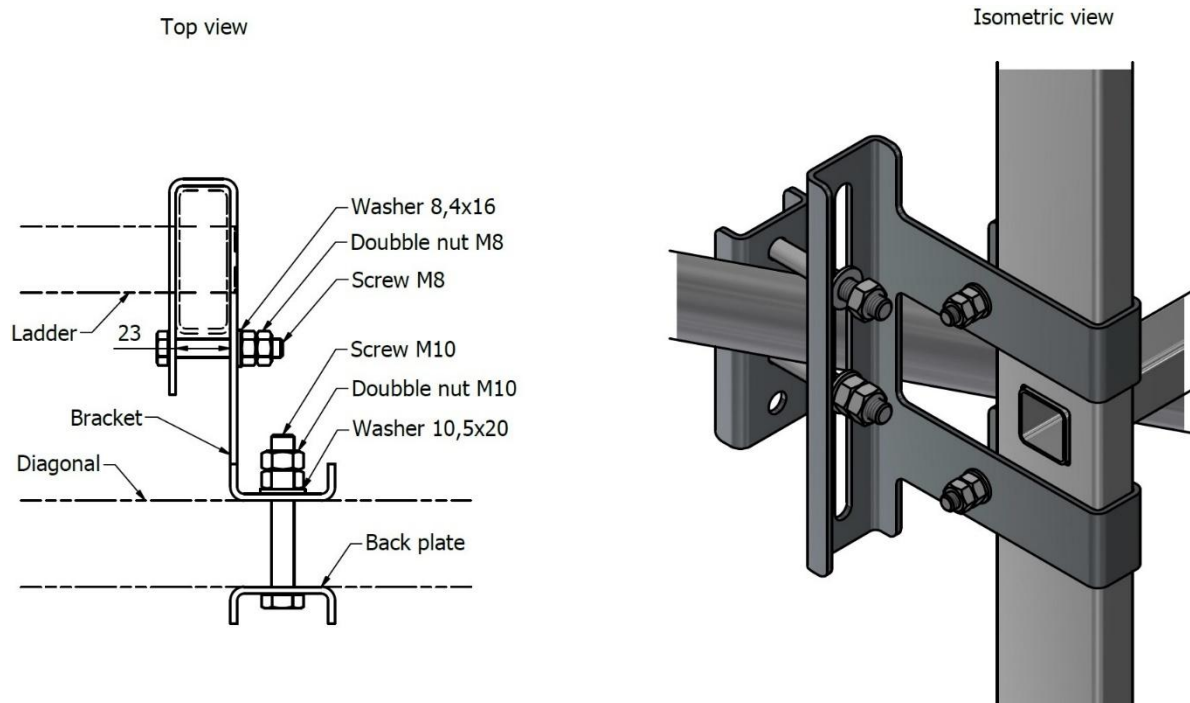

Figure anchoring mark.

3.4 Ladder bracket 105207

Fits in sections with diagonals 40 mm and under. Set consists of 4 x ladder bracket, positioned according to picture of respective section.

Assemble the ladder with the mark on the side of the stile downwards in the section. Position the U-clamps around the stile with its opening towards the diagonal and the angled plate pointing away from the ladder. Assemble with M8-screw, washer and nut. Screw until the distance in the U-clamp is 23 mm and lock with second nut. Put the back plate against the diagonal and assemble with M10, washer and nut. Tighten the nut so the plates or the diagonal does not bend and lock with second nut.



3.5 Ladder bracket 105208

Fits in sections with diagonals 50 mm and over. Set consists of 4 x ladder bracket, positioned according to picture of respective section.

Assemble the ladder with the mark on the side of the stile downwards in the section. Position the U-clamps around the stile with its opening towards the diagonal and the angled plate pointing away from the ladder. Assemble with M8-screw, washer and nut. Tightening until the distance in the U-clamp is 23 mm and lock with second nut. Put the back plate against the diagonal and assemble with M10, washer and nut. Tighten the nut so the plates or the diagonal does not bend and lock with second nut.

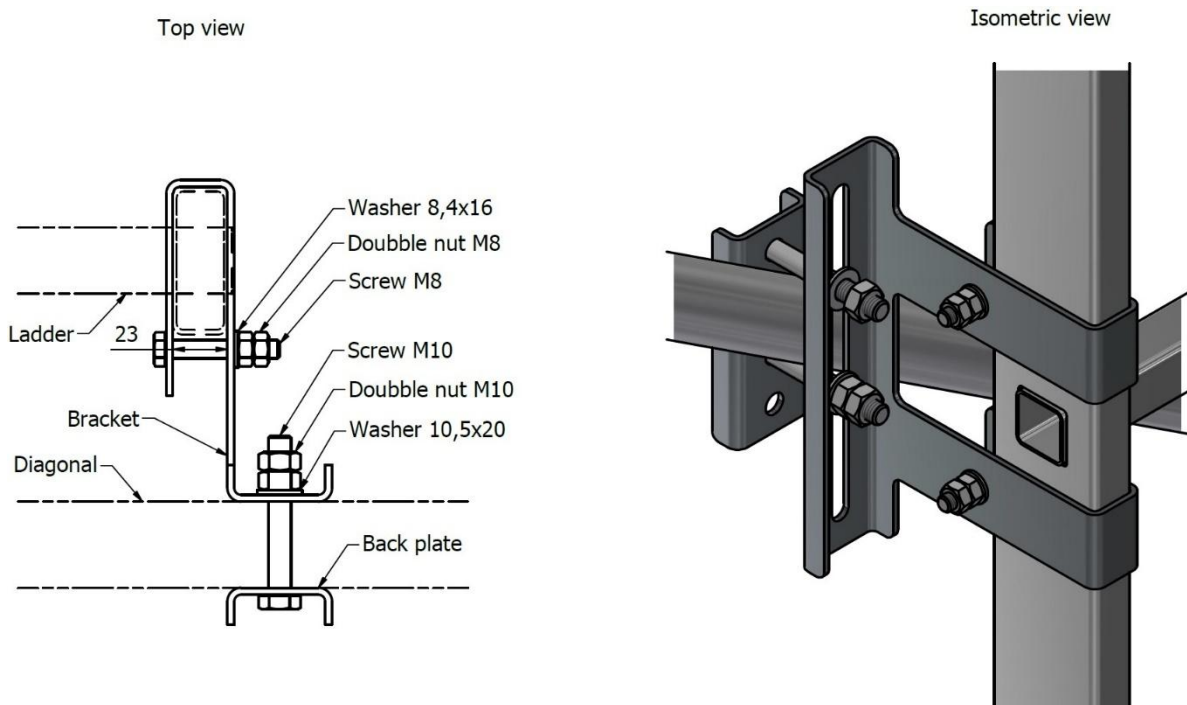

3.6 Cover plate section 20

Secure the nuts with punch marks after tightening.

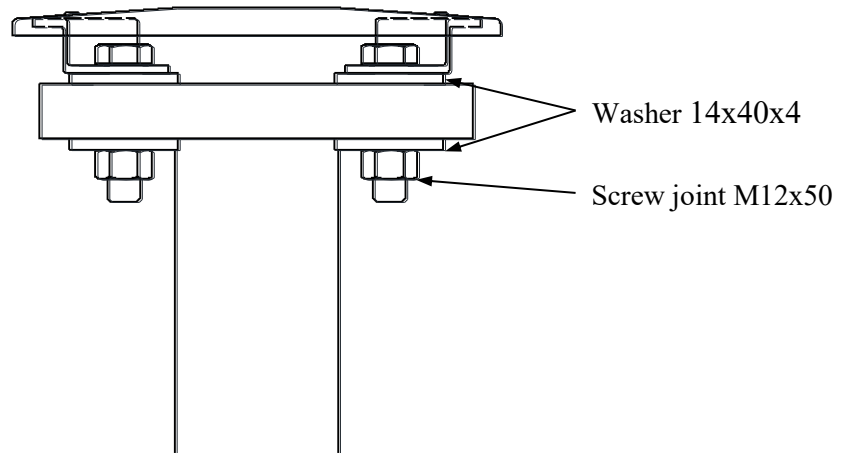

3.7 Ladder joint

When assemble ladder joint 650563, the nut shall be tightened but not so the ladder profile bends. If the tower is erected section by section, ensure that the ladder does not protrude outside the section. If necessary, cut the ladder to size.

External ladder joint

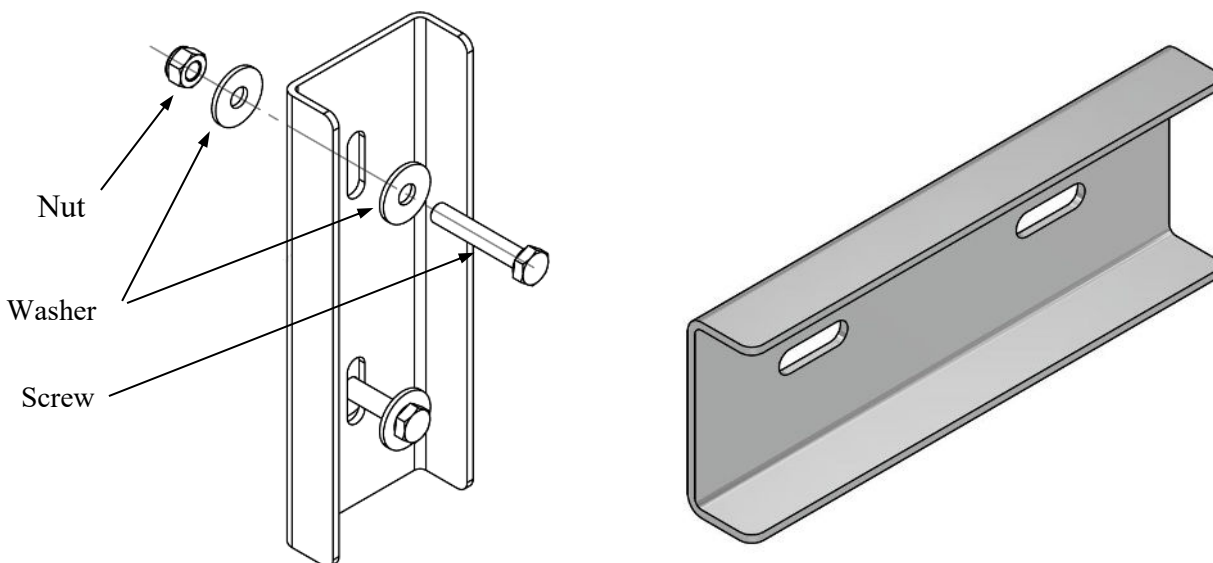

4 ERECTING THE TOWER

4.1 Erecting tower having completely assembled it on the ground

1. Undo the top nut on the foundation bolts. Level the bottom nuts. Place the base plates on the bottom nuts and level the upper surface of the base plates. Ensure that the bottom nuts (the washers) are in close contact with the underside of the base plates. Adjust with the starting-point that the base plates must be as low as possible without any part of them, e.g. the drain pipe, being in contact with the foundation (cf. illustrations chapter 5 "Under casting foundation" in these instructions).
2. Screw on the top nut.
3. Place a lifting strap over the tower's centre of gravity and under a diagonal fixing point

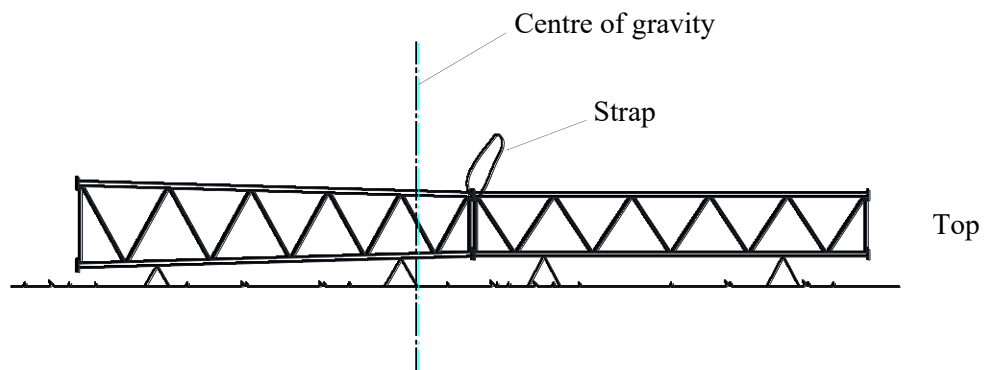

4. Carefully lift the tower with a mobile crane. The lowest section of 11-13 should be stabilized diagonally using lashing straps before lifting the tower. If the bottom section is 8, 9 or 10 the fixing template is to be mounted before lifting according to pictures and table on the next page to stabilize the section diagonally. When the tower is split should the part without horizontal bracing or welded sections be stabilized diagonally using lashing straps before lifting the tower. For masts over 42 m or if the installation engineer is inexperienced, it is recommended that another crane is used to stabilize the bottom end of the tower and prevent it from dragging on the ground

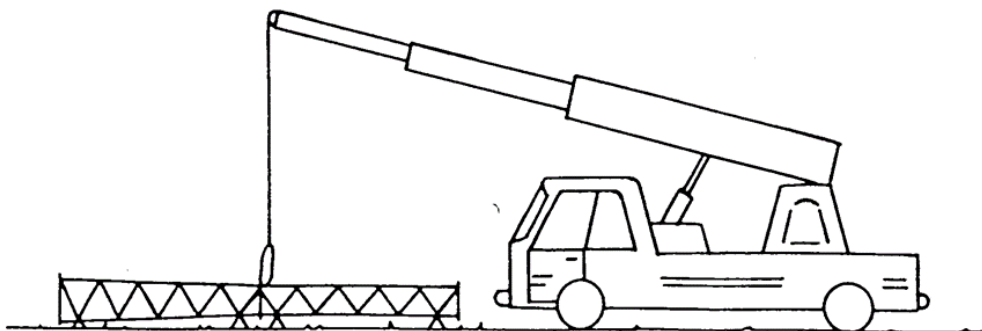

5. Position the tower on the base plates. Screw in the screws between section and base plate and tighten the screws and foundation bolts with torque according to table on page 23 and 25.
6. Checking the straightness of the tower.
 - 6.1 The maximum permissible deviation for the top of the tower is $1/500$ of the tower height.

Diagonally stabilizing of Sections 8, 9, 10, 101 and 102 using the fixing template.

If the bottom section is 8, 9 or 10 the fixing template is to be mounted before lifting according to pictures and table below to stabilize the section diagonally. When the tower is in a vertical position and before it is mounted on the base plates the fixing template is to be loosened and removed.

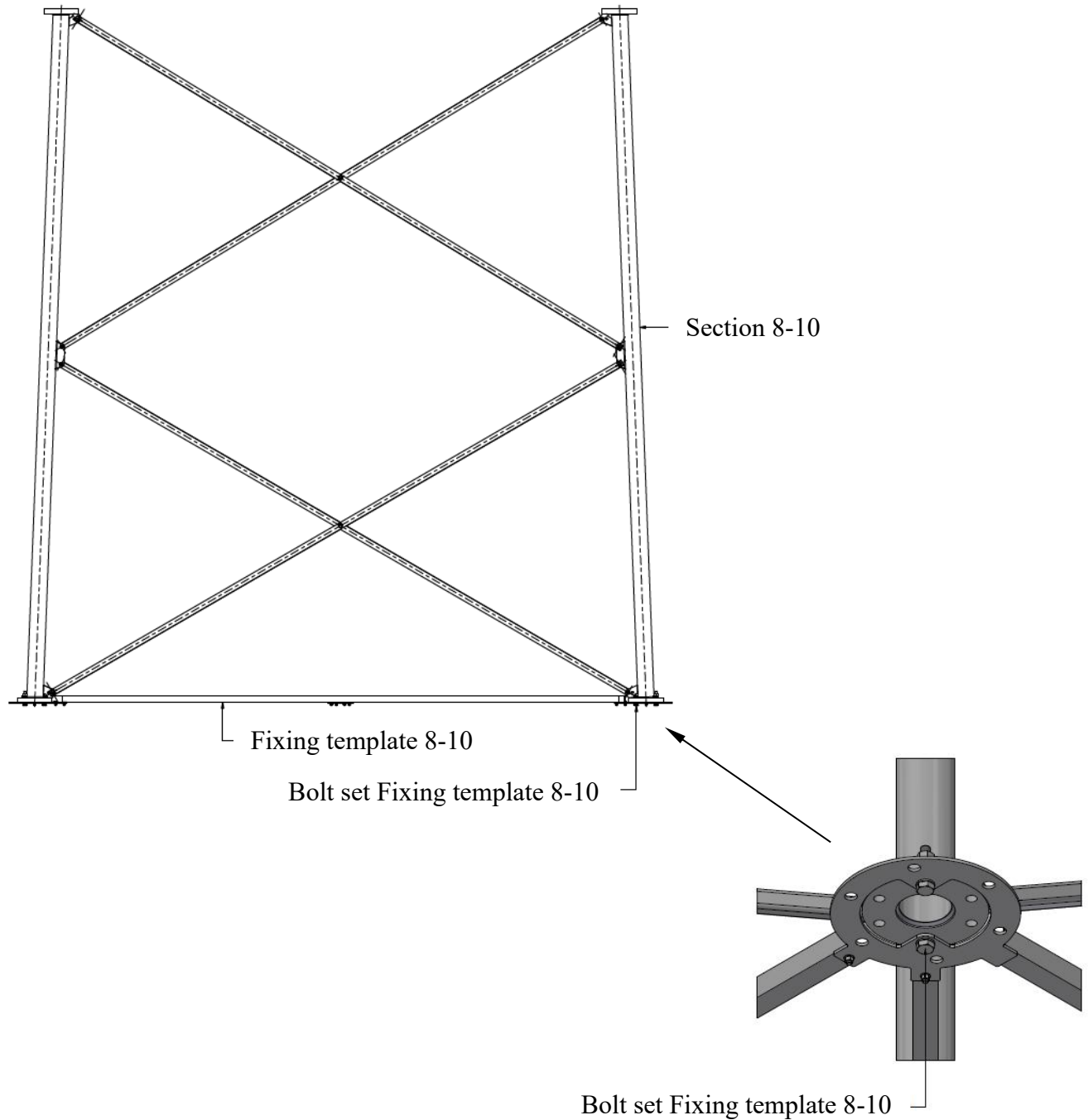

<u>Section</u>	<u>Fixing template</u>	<u>Bolt set</u>
8	102265	108050
9	104220	108050
10, 101, 102	104771	108050

4.2 Joints between base plates and section 8-17

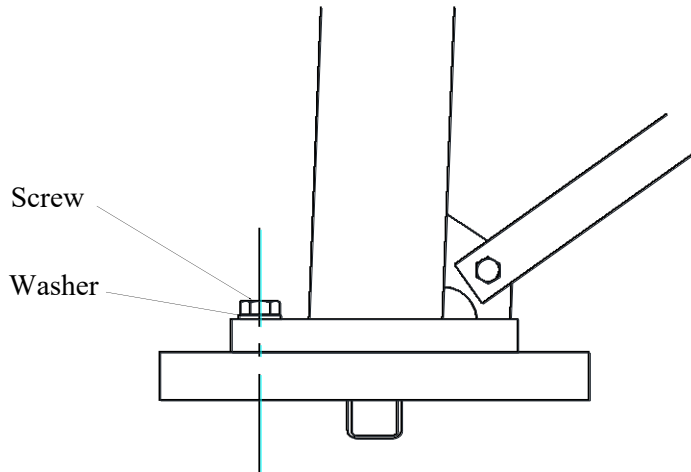

Tighten the screw in the base plates with torque according to the table below.

Section	Part No.	Screw	Torque
8-10	102284	M6S 24x110 8.8 galvanized	712 Nm
11-14	715690	M6S 24x100 8.8 galvanized	712 Nm
15	715689	M6S 22x90 8.8 galvanized	554 Nm
16	715688	M6S 22x90 8.8 galvanized	554 Nm
17	715687	M6S 20x80 8.8 galvanized	412 Nm

5. UNDER CASTING BASE PLATES

5.1 Warranty conditions

Once the tower has been erected the base plates must be under cast. Under casting is required for the tower to have full load-carrying capacity and for the warranty to apply. Under casting of base plates is to be done with the mortar specified, for example, BEMIX* expanding frost proof mortar or equivalent.

The under casting must be somewhat smaller in diameter than the base plate so that water cannot collect between mortar and base plate.

*www.finjabemix.se

5.2 Section 8-17

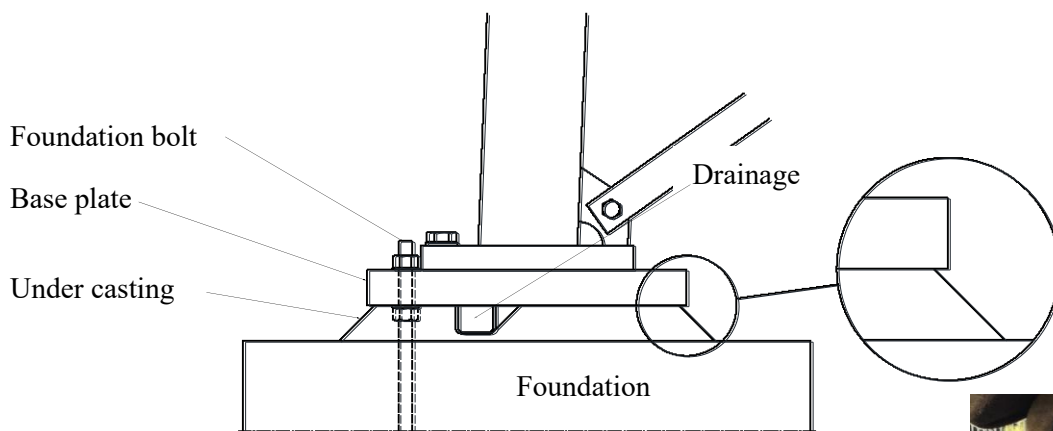

5.3 Section 18-19-20

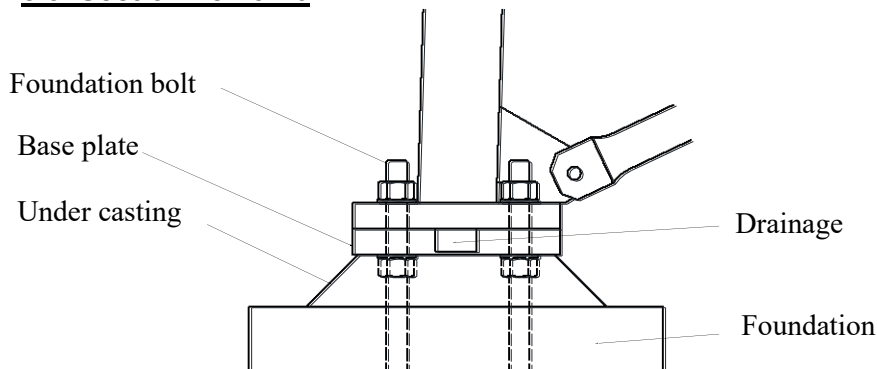

5.4 Section 20 alternative.

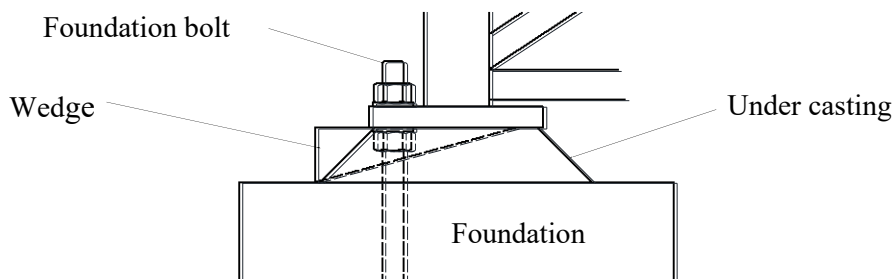

Example of under casting

Drainage holes can be created by means of, for example, a styrofoam wedge below the base plate, which is removed once the concrete has hardened. Make sure that drainage is free from dirt.

6. SPECIFICATIONS

6.1 Torque for tightening screw joints (Does not apply to ladder attachment or flange joints between sections!)

Tightening torque, torque wrench

Dimension	Lubricant Oil
M10	50 Nm
M12	87 Nm
M16	211 Nm
M20	412 Nm
M22	554 Nm
M24	712 Nm
UNC 1"	826 Nm

6.2 Torque for tightening foundation bolts

Tightening torque, torque wrench

Dimension	Lubricant Oil
M20	218 Nm
M24	377 Nm
M30	746 Nm

6.3 Locking with punch mark

Joints that are not secured by torquing must be secured by punch marking nuts according to the figure below.

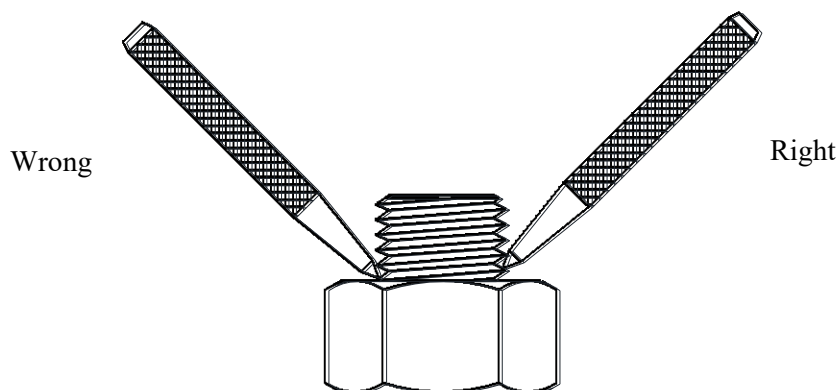

6.4 Weight and measure specifications

<u>Part no.</u>	<u>Description</u>	<u>Weight, kg</u>	<u>Outside diameter mm mast leg</u>
102242	Section 8	1830	139,7 (All variants Section 8)
102246	Section 9	1644	139,7 (All variants Section 9)
102252	Section 10	1450	139,7 (All variants Section 10)
104803	Section 101	1446	139,7 (All variants Section 10)
105272	Section 102	1590	139,7 (All variants Section 10)
100811	Section 11	1100	139,7 (All variants Section 11)
100822	Section 111	1230	139,7 (All variants Section 11)
100812	Section 12	1070	139,7 (All variants Section 12)
100823	Section 121	1200	139,7 (All variants Section 12)
100813	Section 13	1040	139,7 (All variants Section 13)
100824	Section 131	1152	139,7 (All variants Section 13)
100814	Section 14	815	114,3 (All variants Section 14)
100825	Section 141	885	114,3 (All variants Section 14)
100815	Section 15	760	114,3 (All variants Section 15)
100826	Section 151	825	114,3 (All variants Section 15)
100816	Section 16	595	88,9 (All variants Section 16)
100827	Section 161	730	88,9 (All variants Section 16)
100817	Section 17	575	88,9 (All variants Section 17)
100828	Section 171	680	88,9 (All variants Section 17)
100818	Section 18	458	76,1 (All variants Section 18)
100829	Section 181	515	76,1 (All variants Section 18)
100819	Section 19	295	70,0 (All variants Section 19)
100830	Section 191	390	70,0 (All variants Section 19)
100842	Section 193	398	70,0 (All variants Section 19)
100820	Section 20	240	60,3 (All variants Section 20)
102284	Base plate 8-10	79	
715690	Base plate 11-14	63	
715689	Base plate 15	51	
715688	Base plate 16	51	
715687	Base plate 17	30	
791138	Base plate 18	5.4	
791137	Base plate 19	4.8	
726456	Base plate 20	2,7	
650562	Ladder	12	
105207	Ladder bracket set	5	
105208	Ladder bracket set	5	
718836	Cover plate set	2	
102265	Fixing template 8	248	
104220	Fixing template 9	231	
104771	Fixing template 10	214	
712670	Fixing template 11	153	
711497	Fixing template 12	140	
711500	Fixing template 13	127	
711503	Fixing template 14	113	
711514	Fixing template 15	107	
715700	Fixing template 16	94	

715701	Fixing template 17	81
719785	Fixing template 18	50
711166	Fixing template 19	38
711167	Fixing template 20	28

8. OPERATION AND MAINTENANCE

8.1 Operation

Always connect to the Söll fall arrest when climbing.

Personal safety equipment:

- Body harness according to EN361
- Söll fall arrester type comfort²
- Helmet
- Gloves
- Other equipment according to local regulations

8.2 Maintenance

Inspection checkpoints recommended to be done every year.

Main structure:

- No structure components missing
- No diagonal or tower legs damaged
- Drainage holes are open (base plate and diagonals)
- Top cover allows ventilation
- No bolt assembly missing
- Bolt assemblies are tightened
- Foundation bolts are tightened
- Under casting is in place
- Ground connections are correct
- Galvanisation condition

Foundation:

- Concrete condition above ground
- No water stagnation on concrete block

Accessories:

- No bolt assembly missing
- Bolt assemblies are tightened
- Galvanisation condition