

Assembly instruction

Torn DELTA

This assembly instruction has been drawn up in accordance with SS-EN 1090-2 and should be used as guidance for trained installers with expertise in the field of erecting masts and towers.

Scanmast AB reserves the right to make changes, revise and interpret this instruction.

Contents

1. Sections.....	3
1.1 Sections 560-450-340-230	4
1.2 Sections 1160-890-690-560 (HR assembly)	5
2. Floodlights Brackets	6
2.1 Top plate 707950	6
2.2 Floodlight arm for top plate 790927	7
2.2.1 Attachment of floodlights clamp screw M20	8
2.3 Beam for floodlight bracket 709333	9
2.4 Floodlight bracket single 717094 and double 717095	9
2.5 Floodlight arm for beam 790028	10
3. Erectiong Tower	11
5. Undercasting of Base Plates	13
5. Bracket for Electrical Cabinet	14
6. Climbing Barrier	15
7. Operation and Maintenance	16
7.1 Operation.....	16
7.2 Maintenance	16
8. Proposal for inspection Plan	17

1. SECTIONS

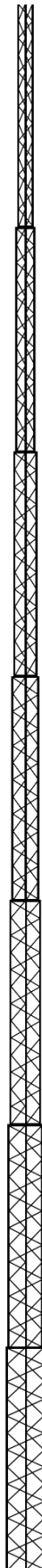
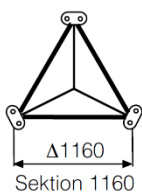
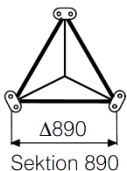
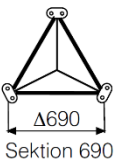
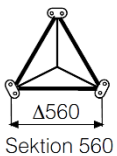

The sections are designated by means of their side measurement in mm.

Sektion	Längd m	Vikt kg	Best.nr
1160	6	444	100806
890	6	330	100805
690	6	274	100804
560	6	214	100803
450	6	150	100802
450	3	75	100854
340	6	107	100801
340	4	75	100851
340	3	55	100852
340	2	36	100853
230	6	80	100800
230	4	55	100848
230	3	41	100849
230	2	28	100850

NB! Drilling, welding or other damage is not permitted.

Tighten the screw joints with torque, where no torque specified use double nuts or lock them by punch marking, see below.

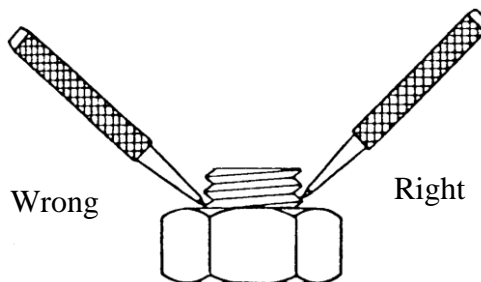

The washer must be located under the nut. Markings on the nuts must be turned outwards so that they are visible after assembly.

1.1 Sections 560-450-340-230

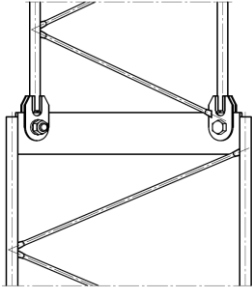

Joint	Order no.	Dim.	Spanner width	Tightening torque
230-340	100807	M16	24	210 Nm (21 kpm)
340-450	100807	M16	24	210 Nm (21 kpm)
450-560	100808	M20	30	410 Nm (42 kpm)

The screw holes can be narrow when assembling joints. If this is the case, assembly can be facilitated by knocking the screws in with a hammer, though not in such a way that the joint lugs or screws are damaged.

To ensure the mast is straight, the following sequence is recommended for erection.

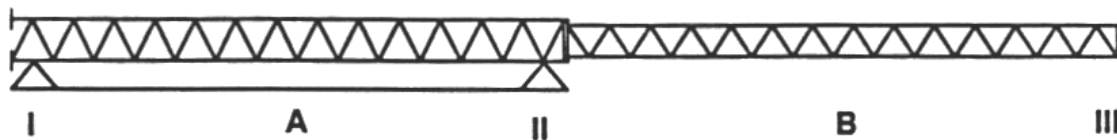

1. Connect section A and B together with screw joints. Tighten the joints so that the screw heads and the nuts are touching.
2. Allow section B to hang freely and tighten the 2 lower screw joints with a torque wrench.
3. Lift section B at III and place a support at III so that support II is disengaged. Tighten the upper screw joint with a torque wrench.

If the tower consists of several sections repeat the procedure.

1.2 Sections 1160-890-690-560 (HR assembly)

The flange joints have a different type of screw joint and tightening method than the other joints. The screw joint has a tested friction between screw and nut and must not be further oiled.

It is important to remember to keep the screw joint in its bag for as long as possible in order to avoid the lubricant being washed away by rain etc.

When tightening HR assembly, first tighten all nuts in the joint to the torque indicated in the table.

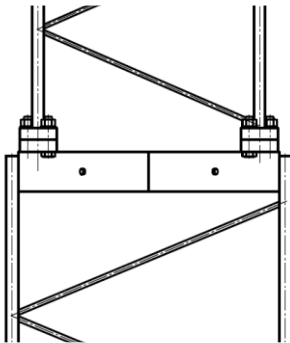

Joint	Order no.	Dim.	Spanner width	Tightening torque
560-690	100809	M24	41	446 Nm
690-890	100809	M24	41	446 Nm
890-1160	100809	M24	41	446 Nm

The position of the nut relative to the bolt threads shall be marked after the first step, using a marking crayon or marking paint, so that the final rotation of the nut relative to the thread in this second step can be easily determined.



0°

Tighten all nuts by a further 60° to obtain the correct pre-load in the joint.



60°

2. FLOODLIGHTS BRACKETS

2.1 Top plate 707950

Fit sections 230, 340 and 450.
To be mounted at the top of the tower.

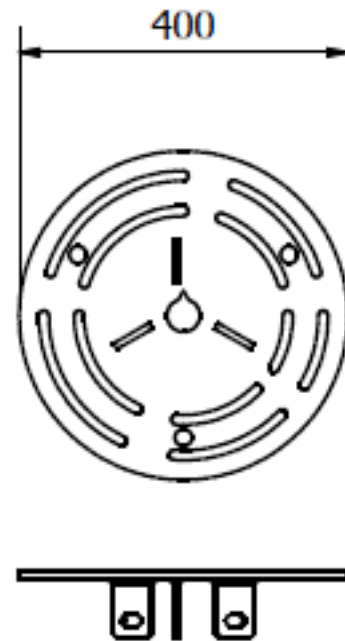

The top plate is mounted with the cut recess in the middle hole upwards and the lower mounting lugs on top of the lower cross plates in the tower top.

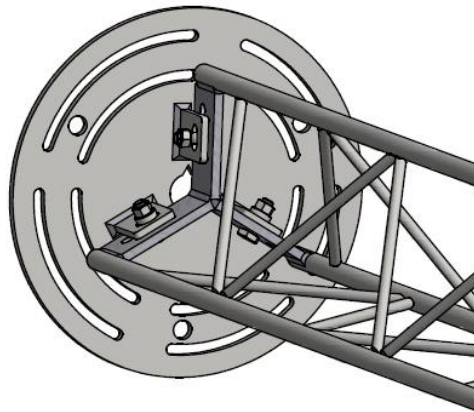

Tighten the nuts with torque and lock by punch marking.

Dim.	Spanner width	Tightening torque
M12	18	86 Nm (8.8 kpm)

2.2 Floodlight arm for top plate 790927.

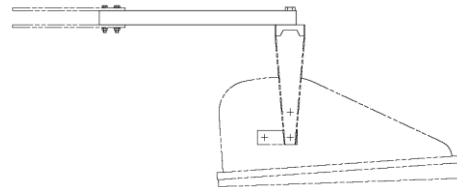
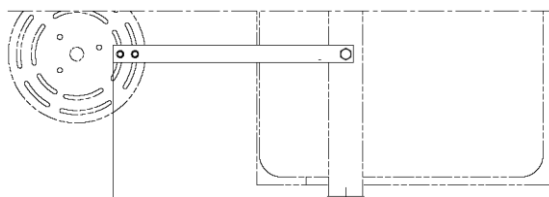

Mounted on plate 707950. Plate 705954 is to be mounted above the floodlight arms. Spacer 719259 is required between the plates when assembling one arm, or two arms with a spacing of less than 120°.

Tighten the nuts with torque and lock by punch marking.

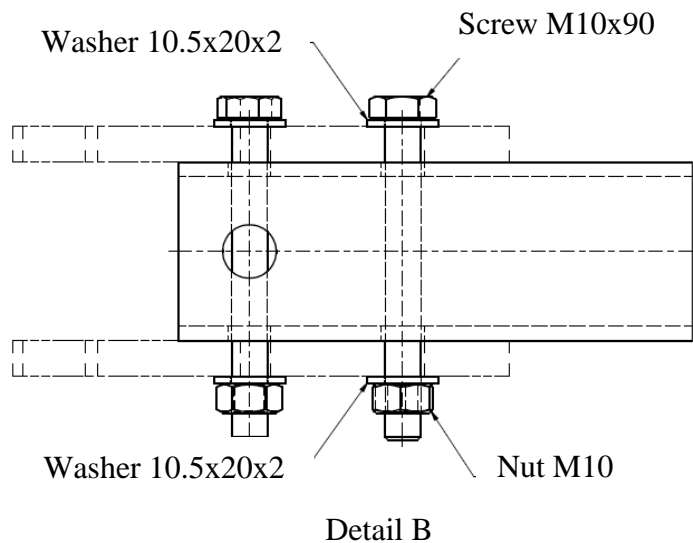
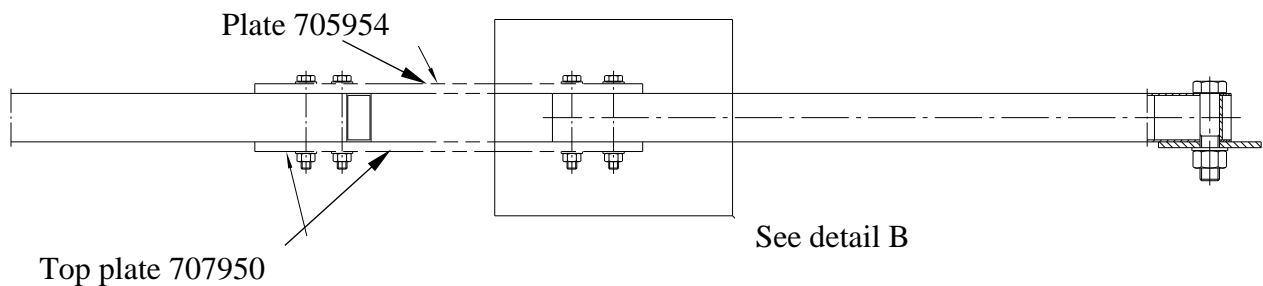

Dim.	Spanner width	Tightening torque
M10	16	50 Nm (51 kpm)

Attachment of floodlights clamp

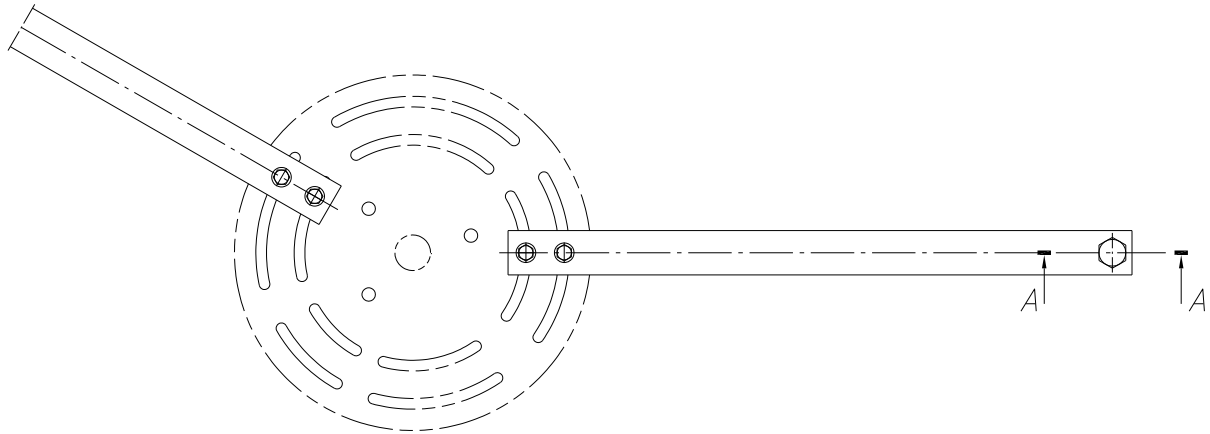

2.2.1 Attachment of floodlights clamp screw M20

Dim.	Spanner width	Tightening torque
M20	30	Controlled hand force

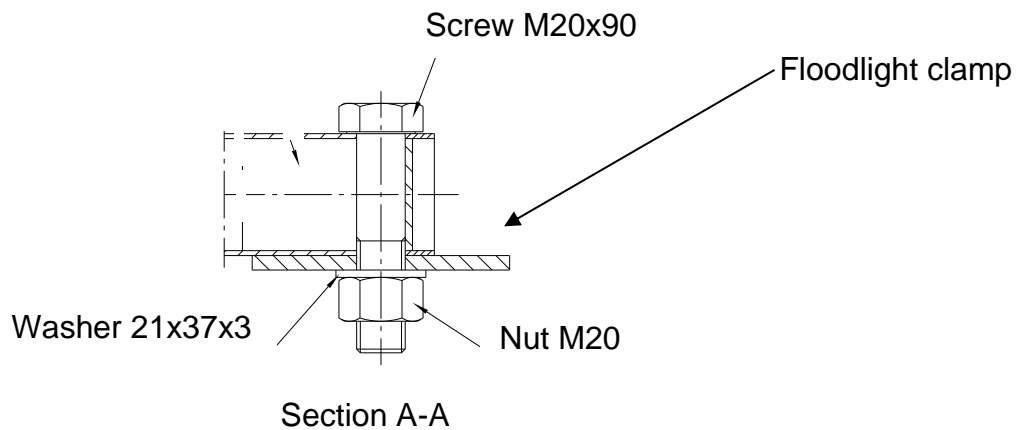

Tighten the nuts using controlled hand force without distorting the profiles and lock by punch marking.

2.3 Beam for floodlight bracket 709333

Mount the beam on the side of the tower. Fits sections 230, 340 and 450.
Tighten the nuts with torque and lock by punch marking.

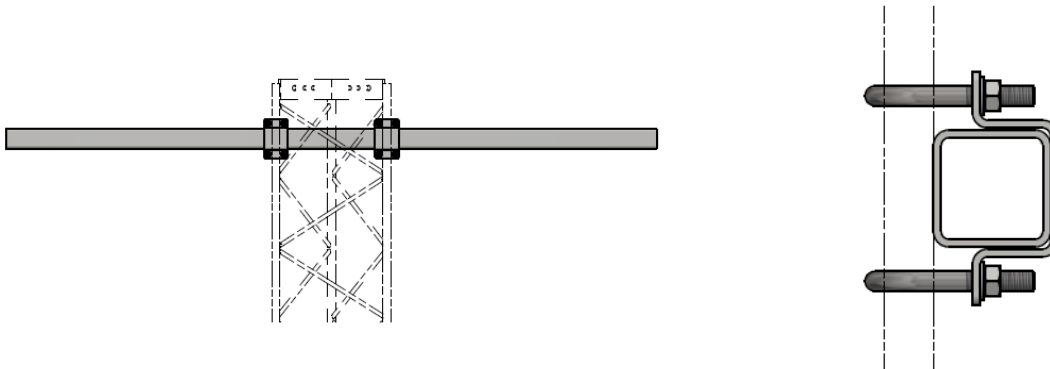

2.4 Floodlight bracket single 717094 and double 717095

To be mounted on the beam for floodlight.
Tighten the nuts with torque and lock by punch marking.

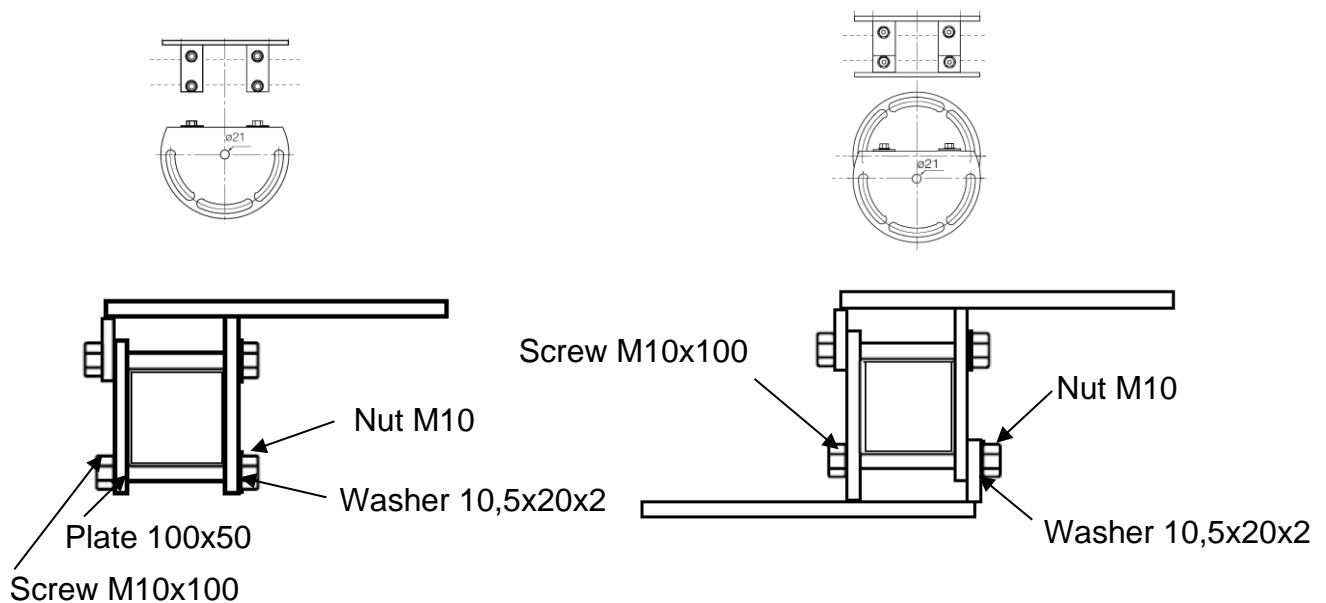

Dim.	Spanner width	Tightening torque
M10	16	50 Nm (5.1 kpm)

2.5 Floodlight arm for beam 790028

To be mounted on beam for floodlight.
 Tighten the nuts with torque (NB! lower torque) and lock by punch marking.
 Fit floodlight clamp (detail A) as shown on page 8.

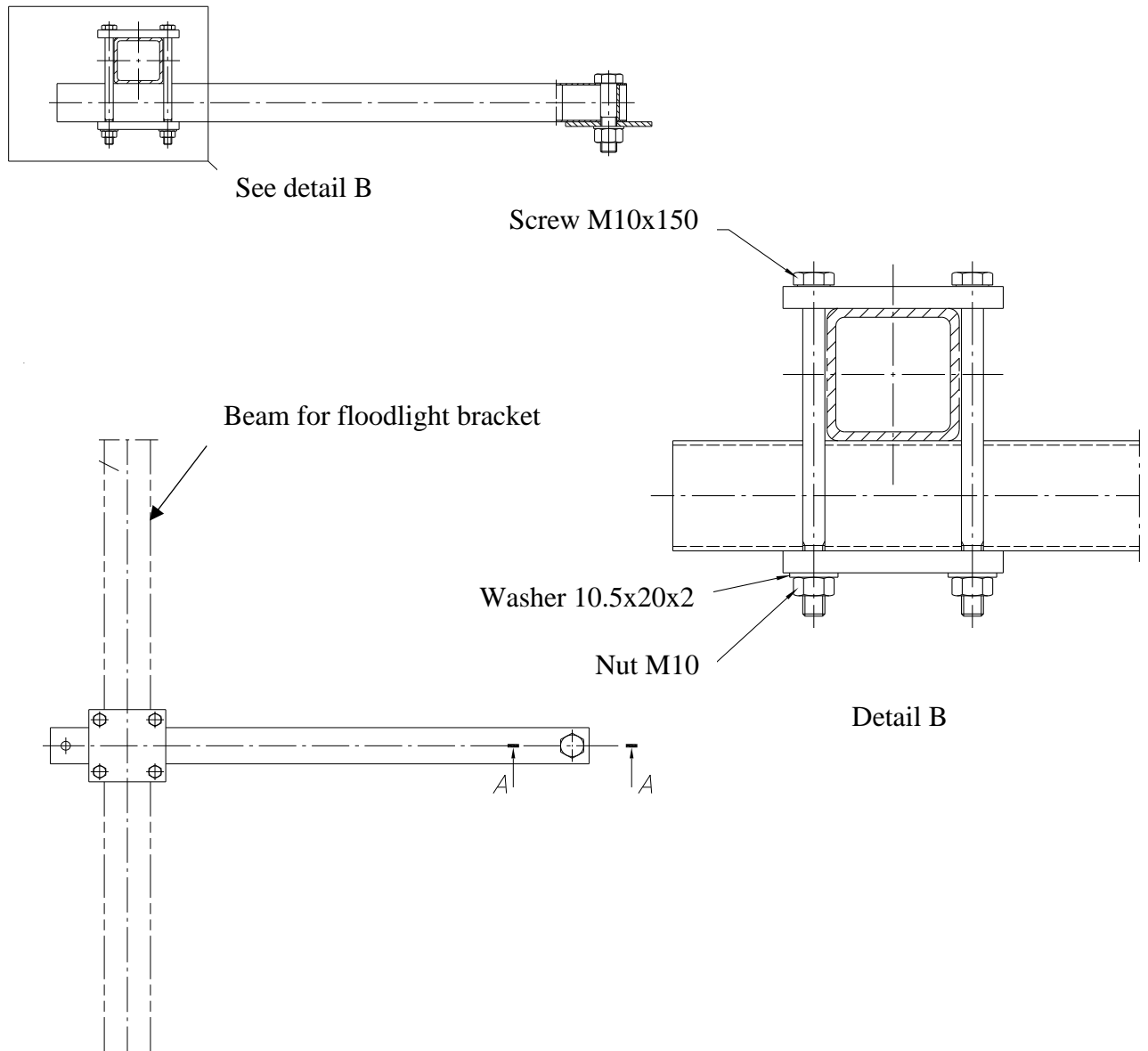

Dim.	Spanner width	Tightening torque
M10	16	24 Nm (2.5 kpm)

3. ERECTIONG TOWER

For bottom section 450 and 340

Fit base plate 727168 at the bottom of the tower. Tighten with a torque wrench.

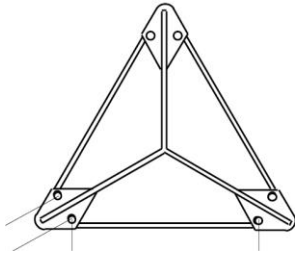

Bottom section	Order no.	Dim.	Spanner width	Tightening torque
340	100807	M16	24	210 Nm (21 kpm)
450	100808	M20	30	410 Nm (42 kpm)

1. Remove the upper nuts on the foundation bolts and adjust the lower nuts so that their top side is in the same horizontal plane and simultaneously as close to the foundation as possible (approx. 50 mm from the foundation to leave room for under casting).

2. Attach a lifting strap in leg directly below the cross plate as in illustration below.

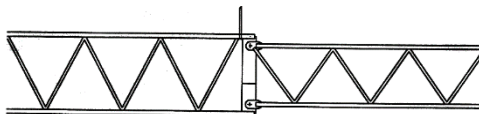

Adjust the crane lorry and lifting strap to the tower's overall height and weight. Weights; see page 3.



Alternative attachment point for lifting.

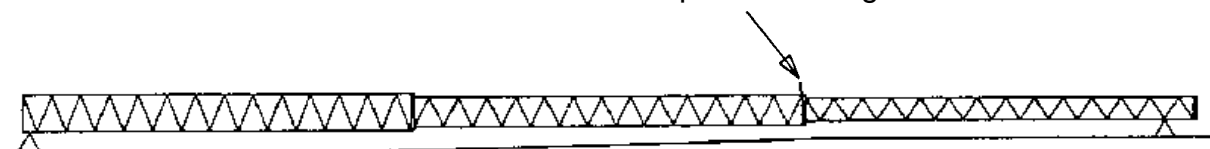

3. Place the tower on the foundation and fit the upper nuts.
4. Check that the tower is standing vertically. Adjust using the nuts if necessary. Ensure that the bottom nuts are in close contact with the underside of the base plates.
5. Tighten the upper nuts with torque. The nuts are normally oiled on delivery.

Bottom section	Foundation bolt	Spanner width	Tightening torque
340	M20	30	218 Nm (22.3 kpm)
450	M20	30	218 Nm (22.3 kpm)
560	M24	36	378 Nm (38.5 kpm)
690	M24	36	378 Nm (38.5 kpm)
890	M24	36	378 Nm (38.5 kpm)
1160	M24	36	378 Nm (38.5 kpm)

5. UNDERCASTING OF BASE PLATES

Under casting is a condition of the warranty. Once the tower has been erected, under casting must be carried out. Under casting is performed with a mortar specifically intended for the purpose that has been compensated for shrinkage, for example, BEMIX* expanding frost-proof mortar or equivalent. The under casting must be somewhat smaller in diameter than the base plate so that water cannot collect between mortar and base plate.

* www.finjabemix.se

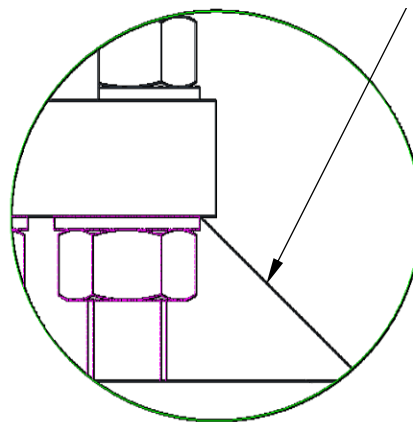
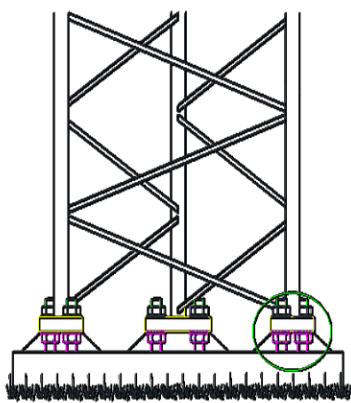

Undercasting



Example of under casting

5. BRACKET FOR ELECTRICAL CABINET

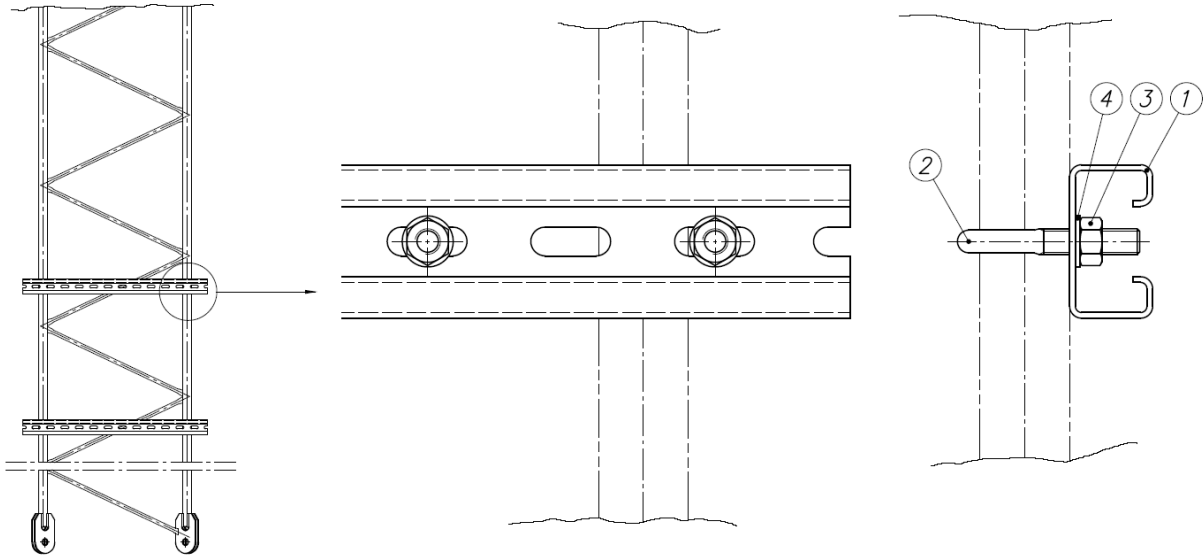

Pos 1: Rail (2x)
Pos 2: Clamp (4x)
Pos 3: Nut M8 (8x)
Pos 4: Washer (8x)

6. CLIMBING BARRIER

1. Place the plates around the section with the pins downwards, standing on the base plates. (See illustration 1). Fit the panels on sections 340 and 450 at H=120 mm resp. H=115 mm above the base plate. (See illustration 2).
2. Pass one panel around the frame leg and the next panel around the next frame leg, then screw them together with the self-tapping screws supplied.
3. Having completed the layer all the way round, repeat the procedure with the next layer above.
4. Guide the pins in the upper panels' lower edge into the holes in the lower panels' top edge and press the panels together before tightening the screws.

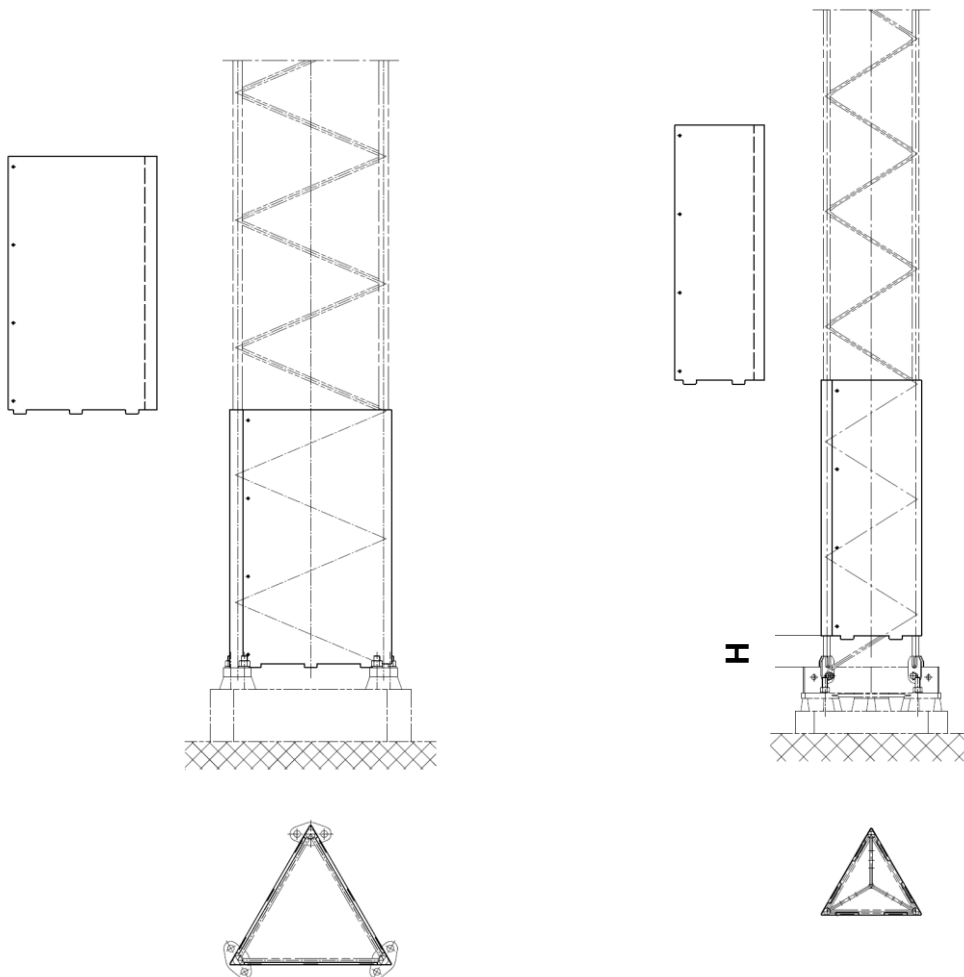

Illustration 1 (560, 690, 890, 1160)

Illustration 2 (340,450)

7. OPERATION AND MAINTENANCE

7.1 Operation

Always connect to the Söll fall arrest when climbing.

Personal safety equipment:

- Body harness according to EN361
- Söll fall arrester type comfort²
- Helmet
- Gloves
- Other equipment according to local regulations

7.2 Maintenance

Inspection checkpoints recommended to be done every year.

Main structure:

- No structure components missing
- No diagonal or tower legs damaged
- No bolt assembly missing
- Bolt assemblies are tightened
- Foundation bolts are tightened
- Under casting is in place
- Ground connections are correct
- Galvanisation condition

Foundation:

- Concrete condition above ground
- No water stagnation on concrete block

Accessories:

- No bolt assembly missing
- Bolt assemblies are tightened
- Galvanisation condition

